



Blue Star 938 WHEEL LOADER PARTS CATALOGUE



前 言

BlueStar938 型装载机零部件图册，是为了便于用户在使用、维护和保养等工作中的方便而编制的，以供在使用过程中查阅及参考，也可以帮助用户了解本车的结构和装配关系。发动机随机已有零部件图册，变速箱另有图册，故本书未编出。

图册按各总成及结构布局绘制出了各零部件的图形及相互关系。凡不可拆卸的部件（焊接件、铆合件），一般只标出部件代号，不另列其组成零件。明细表编制了名称、代号和数量。

随着技术更新和生产的不断发展，产品将不断改进提高，故本图册的部分内容可能与实物不相一致。敬请谅解！

FOREWORD

BLUESTAR938 LOADER PARTS CATALOGUE IS ORDER TO FACILITATE THE USER IN THE USE, REPAIR AND MAINTENANCE WORK IN THE CONVENIENCE OF PREPARED, FOR IN THE COURSE OF INSPECTION AND REFERENCE, CAN ALSO HELP USERS TO UNDERSTAND THE STRUCTURE AND ASSEMBLY OF THE VEHICLE BETWEEN. RANDOM BOOKS HAVE BEEN THE ENGINE PARTS, GEARBOX HAD ANOTHER ATLAS, SO THIS BOOK IS NOT TO COMPILE.

PHOTO BY THE ASSEMBLY AND STRUCTURE OF THE LAY-OUT OF MAP OUT THE VARIOUS PARTS OF THE GRAPHICS AND THE RELATIONSHIP BETWEEN. ALL REMOVABLE PARTS ARE NOT GENERALLY MARKED, ONLY THE CODE PARTS, DO NOT SEPARATE OUT ITS COMPONENT PARTS, SCHEDULE PRODUCED A NAME, CODE AND QUANTITY.

WITH THE CONSTANT TECHNOLOGICAL UPGRADING AND PRODUCTION DEVELOPMENT, PRODUCT IMPROVEMENT WILL CONTINUE TO INCREASE, SO THIS PART OF THE ATLAS MAY NOT CONSISTENT WITH THE PHYSICAL. PLEASE UNDER-
STAND!

目 录

CONTENTS

1 传动系统.....1	1 TRANSMISSION SYSTEM.....1
2 变矩器总成.....3	2 TORQUE CONVERTER ASSEMBLY.....3
3 减压阀总成.....9	3 SAFETY VALVE ASSEMBLY.....9
4 变速箱总成.....11	4 TRANSMISSION ASSEMBLY.....11
5 输入轴总成.....17	5 INPUT SHAFT ASSEMBLY.....17
6 倒档轴总成.....21	6 REVERSE GEAR SHIFT ASSEMBLY.....21
7 中间轴总成.....25	7 CLUTCH SHIFT.....25
8 输出轴总成.....29	8 OUTPUT SHIFT ASSEMBLY.....29
9 高低档拨叉机构.....31	9 SHIFT YOKE MECHANISM.....31
10 变速箱操纵阀总成.....33	10 TRANSMISSION CONTROL VALVE.....33
11 前后桥总成.....35	11 FRONT/REAR AXLE ASSEMBLY.....35
12 主减速器总成.....37	12 MAIN REDUCER ASSEMBLY.....37
13 轮边减速器总成.....41	13 WHEEL-END-REDUCER ASSEMBLY.....41
14 制动器总成.....45	14 PLIERS ASSEMBLY.....45
15 变速箱支架总成.....47	15 TRANSMISSION BRACKET ASSEMBLY.....47
16 轮辋总成.....49	16 RIM ASSEMBLY.....49
17 制动系统.....51	17 BRAKE SYSTEM.....51
18 空气加力泵.....57	18 BOOSTER.....57
19 紧急与停车制动器总成.....59	19 EMERGENCY AND PARKING BRAKE ASSEMBLY.....59
20 传动液压系统.....61	20 TRANSMISSION HYDRAULIC SYSTEM.....61
21 回油滤清器总成.....65	21 Return Oil Filter Assembly.....65
22 转向液压系统.....67	22 STEERING HYDRAULIC SYSTEM.....67
23 转向油缸.....71	23 STEERING CYLINDER.....71
24 转向器总成.....73	24 STEERING UNIT ASSEMBLY.....73
25 单路稳定分流阀总成.....77	25 SINGLE STABLE DIVIDING VALVE ASSEMBLY.....77
26 工作装置液压系统.....79	26 WORKING HYDRAULIC SYSTEM.....79

目 录

CONTENTS

27 工作分配阀	85	27 WORKING DISTRIBUTION VALVE	85
28 齿轮泵	89	28 GEAR PUMP	89
29 转斗油缸	91	29 TILT CYLINDER	91
30 举升油缸	93	30 LIFTING CYLINDER	93
31 工作装置总成	95	31 WORKING EQUIPMENT ASSEMBLY	95
32 前车架总成	99	32 FRONT FRAME ASSEMBLY	99
33 后车架总成	103	33 REAR FRAME ASSEMBLY	103
34 摆动架总成	107	34 OSCILLATING FRAME ASSEMBLY	107
35 配重铁总成	109	35 COUNTERWEIGHT ASSEMBLY	109
36 标尺总成	111	36 RULER ASSEMBLY	111
37 左右侧地板总成	113	37 L/R SIDE FLOOR	113
38 柴油箱总成	115	38 FUEL TANK ASSEMBLY	115
39 机油箱总成	117	39 ENGINE OIL TANK ASSEMBLY	117
40 发动机罩总成	121	40 ENGINE HOODL ASSEMBLY	121
41 转向操纵机构	123	41 STEERING CONTROL MECHANISM	123
42 变速箱操纵机构总成	125	42 TRANSMISSION CONTROL MECHANISM ASSEMBLY	125
43 高低速工作分配阀操纵机构	129	43 H/L SPEED CONTROL MECHANISM FOR WORKING BALVE ASSEMBLY	129
44 地板与操纵台总成	131	44 FLOOR AND CONTROL BOARD ASSEMBLY	131
45 驾驶室总成(一)	133	45 CAB ASSEMBLY(ONE)	133
46 驾驶室总成(二)	135	46 CAB ASSEMBLY(TWO)	135
47 加油机构	137	47 ACCELERATOR MECHANISM	137
48 柴油机装置	139	48 DIESEL ENGINE INSTALLATION	139
49 仪表盘总成	143	49 CONTROL PANNEL ASSEMBLY	143
50 电器系统	145	50 ELECTRIC SYSTEM	145

传动系统 Transmission system

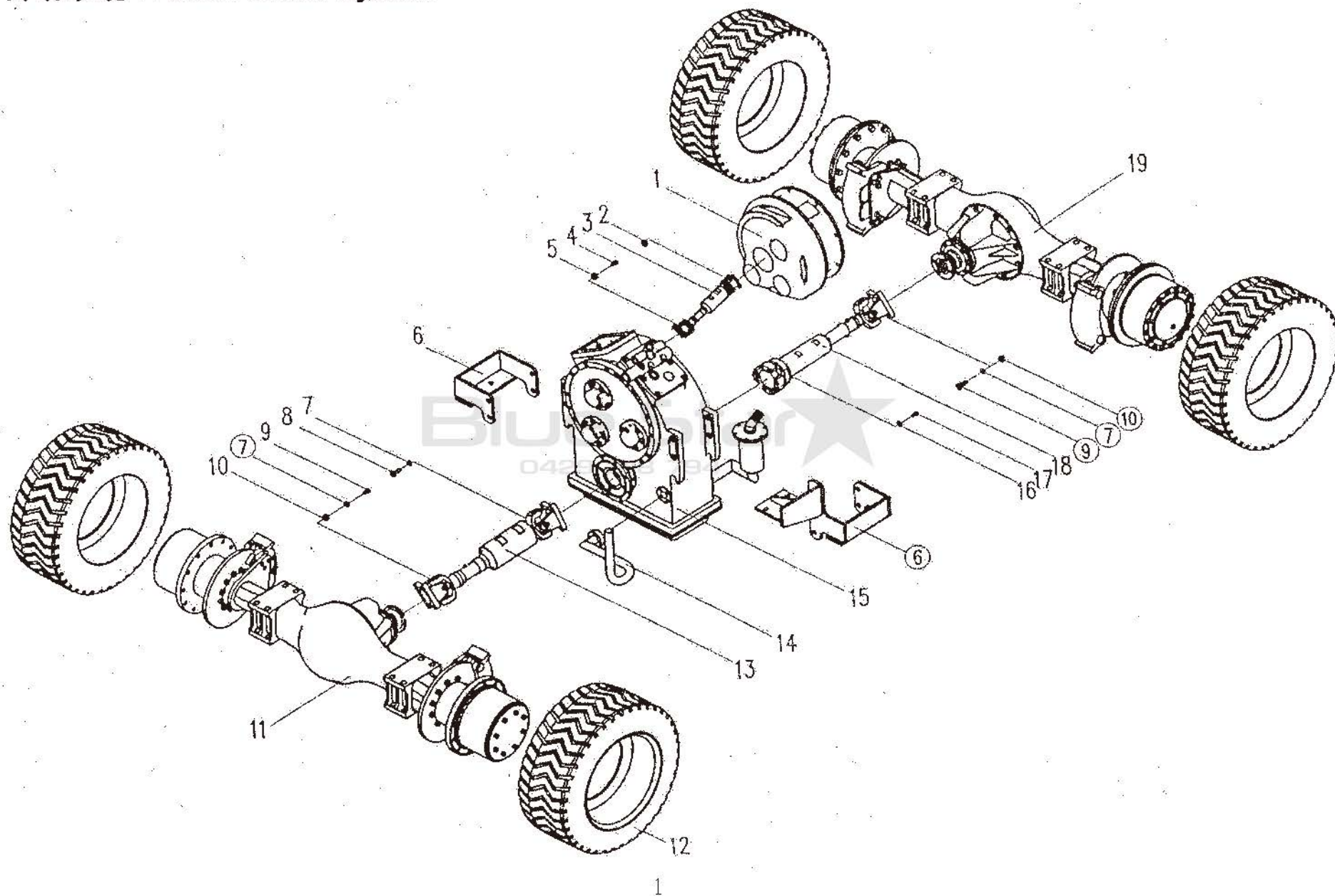

传动系统 Transmission system

序号 Ser. No	零件名称 Part Name		数量 Qty	零件代号 Part No
1	YJ320B 变矩器	Torque converter	1	YJ320B
2	螺母 M12	Nut M12	4	GB889-86
3	主传动轴	Main driving shaft	1	
4	螺栓 M12×1.5×35	Bolt M12×1.5×35	4	GB5786-86
5	螺母 M12×1.5	Nut M12×1.5	4	GB889-86
6	变速箱支架总成	Gear box bracket	1	
7	垫圈 14	Washer 14	12	GB93-87
8	螺栓 M14×1.5×30	Bolt M14×1.5×30	4	GB5786-86
9	螺栓 M14×1.5×45	Bolt M14×1.5×45	8	GB5786-86
10	螺母 M14×1.5	Nut M14×1.5	8	GB6171-86
11	前驱动桥总成	Front driving axle assembly	1	
12	轮胎轮辋总成	Rim assembly	4	
13	前传动轴	Front driving shaft	1	
14	加油管	Oil pipe	1	
15	变速箱总成	Gear box	1	
16	垫圈 10	Washer 10	4	GB93-87
17	螺栓 M10×1.25×45	Bolt M10×1.25×45	4	GB5785-86
18	后传动轴	Rear driving shaft	1	
19	后驱动桥总成	Rear driving axle assembly	1	

变矩器总成 Torque Converter Assembly

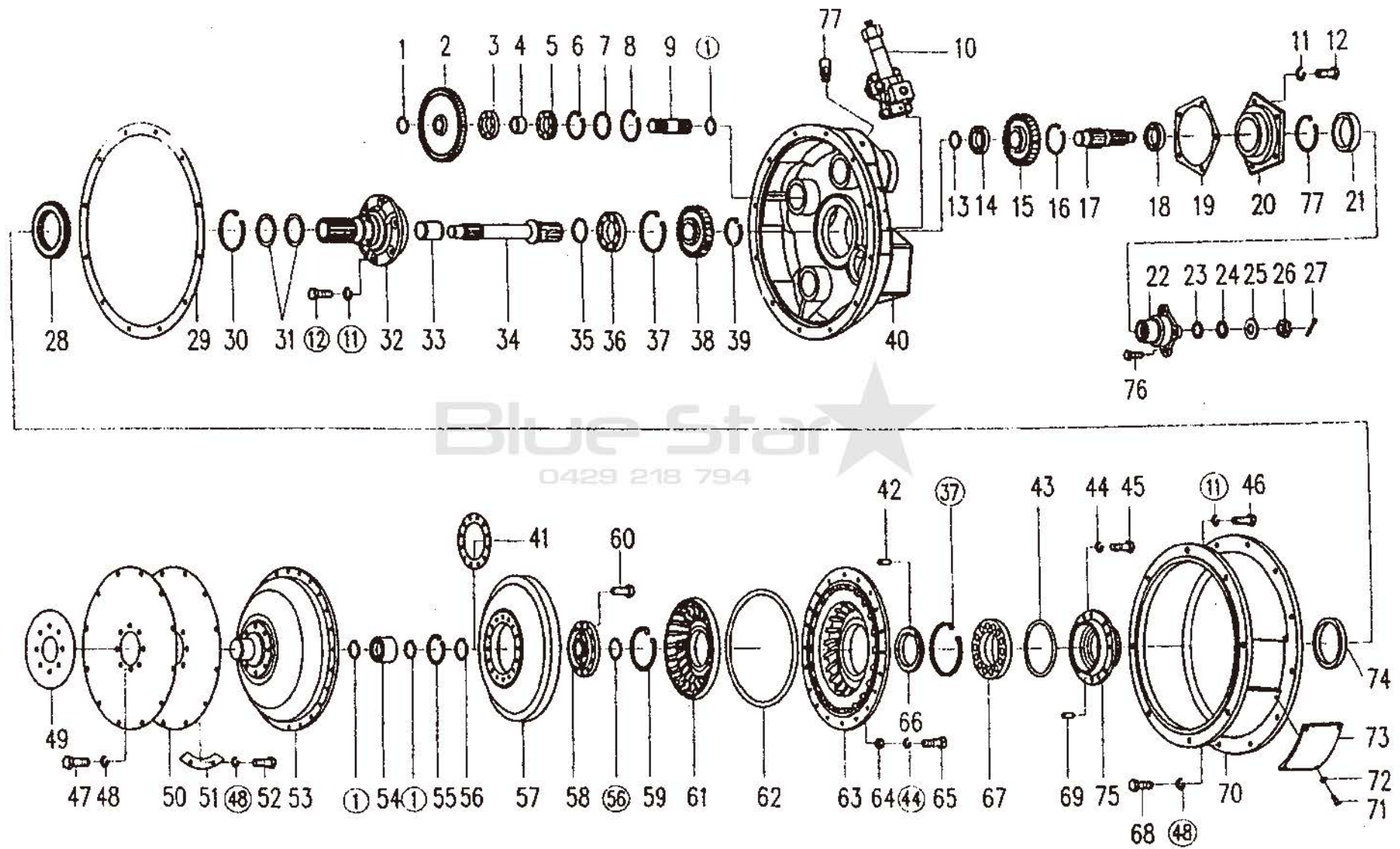

变矩器总成 Torque Converter Assembly

序号 Ser. No	零件名称 Part Name		数量 Qty	零件代号 Part No
1	挡圈 30	Snap ring 30	6	GB894.1-86
2	驱动油泵被动齿轮	Driven gear	3	ZL30F.11-39
3	轴承 206	Bearing 206	3	GB276-89
4	套	Sleeve	3	ZL30F.11-40
5	轴承 50206	Bearing 50206	3	GB277-89
6	止动环 62/67.7	Lock ring 62/67.7	3	GB305-89
7	垫圈	Washer	3	ZL30F.11-3
8	挡圈 68	Snap ring 68	3	GB893.1-86
9	驱动油泵轴	Drive pump shaft	3	ZL30F.11-2
10	减压阀总成	Relief valve asy	1	ZL30F.11.2
11	垫圈 12	Washer 12	19	GB93-87
12	螺栓 M12x30	Bolt M12x30	5	GB5783-86
13	挡圈 35	Snap ring 35	1	GB894.1-86
14	轴承 307	Bearing 307	1	GB276-89
15	被动齿轮	Driven gear	1	ZL30F.11-18
16	挡圈 90	Snap ring 90	1	GB893.1-86
17	输出轴	Output shaft	1	ZL30F.11-15
18	轴承 308	Bearing 308	1	GB276-89
19	密封垫	Gasket	1	ZL30F.11-9
20	油封法兰	Seal flange	1	ZL30F.11-11
21	油封 55x82x16	Oil seal 55x82x12	1	
22	输出连接法兰	Coupling flang on output shaft	1	ZL30F.11-12
23	垫圈	Washer	1	ZL30F.11-13
24	密封垫	Gasket	1	ZL30F.11-17
25	垫圈	Washer	1	ZL30F.11-16
26	六角槽型螺母 M24x1.5	Hex slot nut M24x1.5	1	ZL30F.11-14
27	销 5x45	Pin 5x45	1	GB91-86

变矩器总成 Torque Converter Assembly

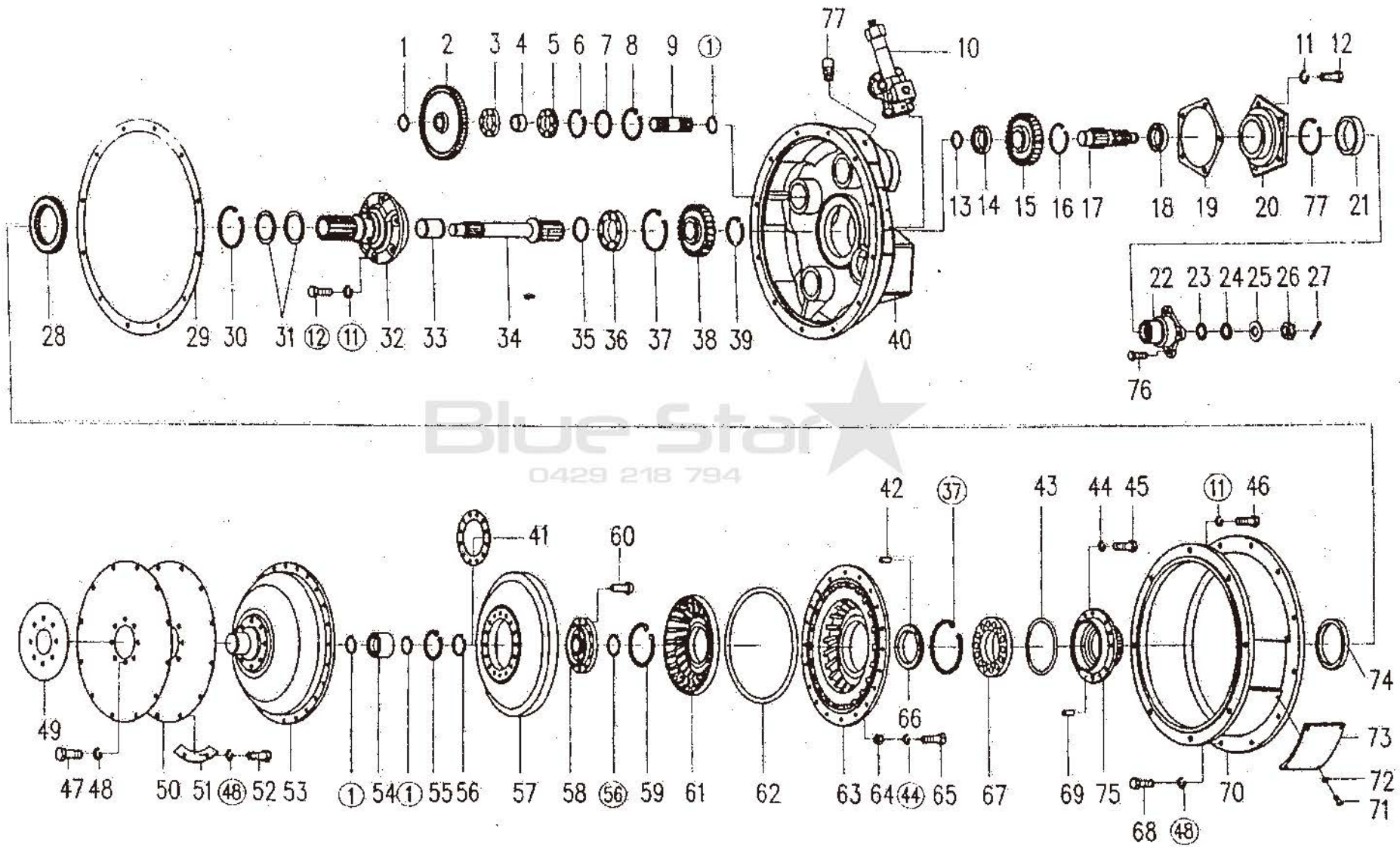

变矩器总成 Torque Converter Assembly

序号 Ser. No	零件名称 Part Name		数量 Qty	零件代号 Part No
28	驱动油泵主动齿轮	Driving gear on drive pump	1	ZL30F. 11-20
29	垫片	Boat	1	ZL30F. 11-38
30	挡圈 100	Snap ring 100	1	GB894. 1-86
31	密封环 80	Seal ring 80	2	ZL30F. 11-19
32	导轮座	Stator boss	1	ZL30F. 11-5
33	套	Sleeve	1	Z130F. 11-10
34	主动轴	Driving shaft	1	Z130F. 11-7
35	密封环 60	Seal ring 60	1	ZL30F. 11-8
36	轴承 310	Bearing 310	1	GB276-89
37	挡圈 110	Snap ring 110	2	GB893-86
38	主动齿轮	Driving gear	1	ZL30F. 11-6
39	挡圈 48	Snap ring 48	1	GB894. 1-86
40	变矩器壳体	Case	1	Z130F. 11-1
41	垫板	Spacing plate 18 794	1	ZL30F. 11-29
42	销 A6×20	Pin A6×20	1	GB879-86
43	O型圈 128×3.55	O ring 128×3.55	1	GB3452. 1-82
44	垫圈 8	Washer 8	32	GB93-87
45	螺栓 M8×22	Bolt M8×22	8	GB5783-86
46	螺栓 M10×35	Bolt M10×35	12	GB5783-86
47	螺栓 M10×20	Bolt M10×20	8	GB5783-86
48	垫圈 10	Washer 10	36	GB93-87
49	垫板	Spacing plate	1	ZL30F. 11-33
50	弹性板 (320B)	Flexibility plank	2	(B) ZL30F. 11-30
51	双联垫片	Double connected mat slice	6	(B) ZL30F. 11-34
52	螺栓 M12×25	Bolt M12×25	8	GB5783-86
53	联接轮	Coupling wheel	1	(B) ZL30F. 11-32
54	滚针轴承 4074106	Needle roller bearing 4074106	1	JB3588-84

变矩器总成 Torque Converter Assembly

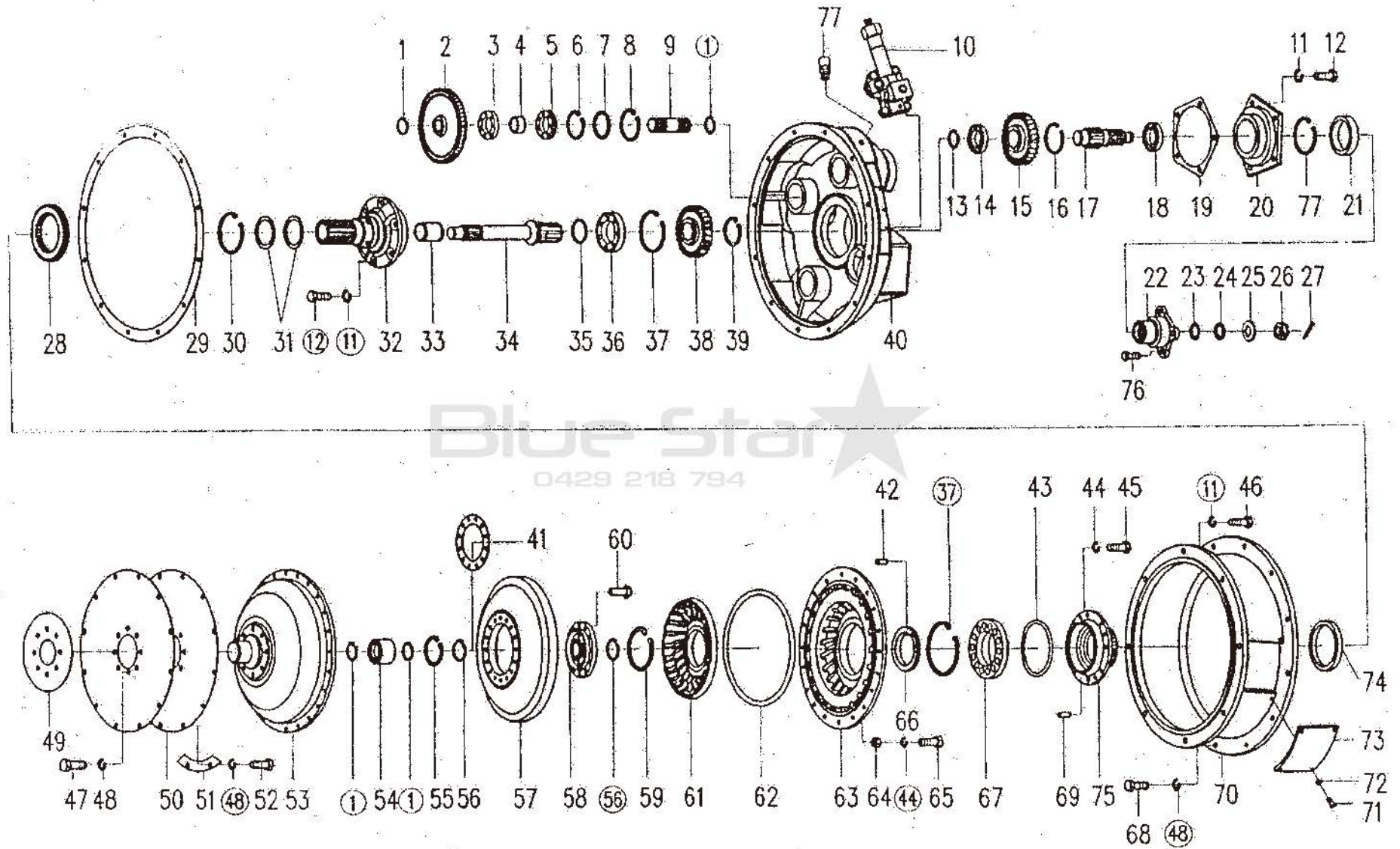

变矩器总成 Torque Converter Assembly

序号 Ser. No	零件名称 Part Name		数量 Qty	零件代号 Part No
55	挡圈 55	Snap ring 55	1	GB893.1-86
56	挡圈 38	Snap ring 38	2	GB894.1-86
57	涡轮	Turbine	1	ZL30F.11-37
58	涡轮座	Turbine boss	1	ZL30F.11-28
59	挡圈 60	Snap ring 60	1	GB894.1-86
60	铆钉 8×30	Rivet 8×30	12	GB869-86
61	导轮	Stator	1	ZL30F.11-27
62	O型圈 339×3.5	O ring 339×3.5	1	GB1235-79
63	泵轮	Impeller	1	ZL30F.11-25
64	螺母 M8	M8	24	GB6170-86
65	螺栓 M8x30	Bolt M8x30	24	GB5781-86
66	隔环	Isolating ring	1	ZL30F.11-24
67	轴承 D212	Bearing cage D212	1	GB276-89
68	螺栓 M10x30	Bolt M10x30	12	GB5783-86
69	定位销	Set pin	4	ZL30F.11-22
70	飞轮壳中节	Mid-segment for flywheel case	1	(B)ZL30F.11-26
71	螺栓 M6x10	Bolt M6x15	8	GB67-85
72	垫圈 6	Washer 6	8	GB93-87
73	观察盖	Sight cap	1	(B)ZL30F.11-50
74	油封 100×120×13	Oil seal 100×120×13	2	
75	泵轮座	Impeller boss	1	ZL30F.11-21
76	螺栓	Bolt	4	ZL30F.11-23
77	接头总成	Tie-in assembly	1	

减压阀总成 Safety Valve Assembly

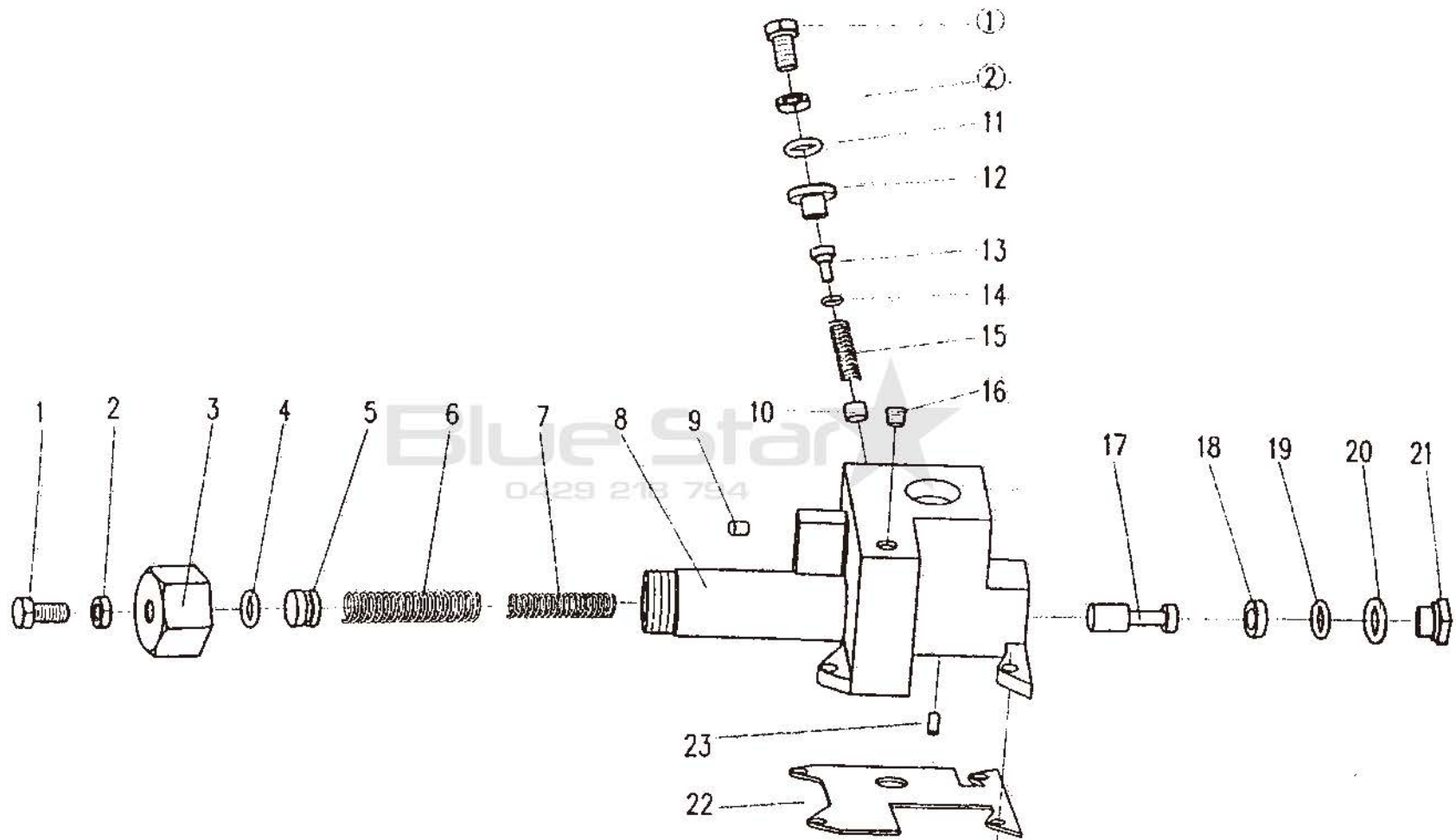

减压阀总成 Safety Valve Assembly

序号 NO.	零件名称 PART NAME		数量 QTY	零件代号 PART NO
1	螺栓 M10x30	BOLT M10x30	2	GB5783-86
2	螺母 M10	NUT M10	2	GB6170-86
3	压盖	CAP	1	ZL30F. 11. 2-2
4	O 形圈 14x2.65	O RING 14x2.65	1	GB3452. 1-82
5	压盖	CAP	1	ZL30F. 11. 2-6
6	弹簧	SPRING	1	ZL30F. 11. 2-3
7	弹簧	SPRING	1	ZL30F. 11. 2-4
8	减压阀体	VALVE BLOCK	1	YJ315X. 11. 2-1
9	堵塞	PLUG	1	YJ315X. 11. 2-7
10	柱塞	POLE PLUG	1	YJ315X. 11. 2-9
11	垫圈 10	WASHER 10	1	JB1002-77
12	螺塞	THREAD PLUG	1	YJ315X. 11. 2-14
13	定位轴	POSITION SHAFT	1	YJ315X. 11. 2-13
14	O 形圈 13.2x2.65	O RING 13.2x2.65	1	GB3452. 1-82
15	弹簧	SPRING	1	YJ315X. 11. 2-12
16	螺塞 ZG1/4"	PLUG	1	Q/ZB285-77
17	减压阀杆	VALVE SPOOL	1	ZL30F. 11. 2-5
18	压盖	CAP	1	ZL30F. 11. 2-11
19	O 形圈 21.2x2.65	O RING 21.2x2.65	1	GB3452. 1-82
20	垫圈 24	WASHER 24	1	JB1002-77
21	螺塞	THREAD PLUG	1	ZL30F. 11. 2-10
22	纸垫	PAPER GASKET	1	YJ315X. 11. 2-15
23	套	SLEEVE	1	YJ315X. 11. 2-8

变速箱总成 Transmission Assembly

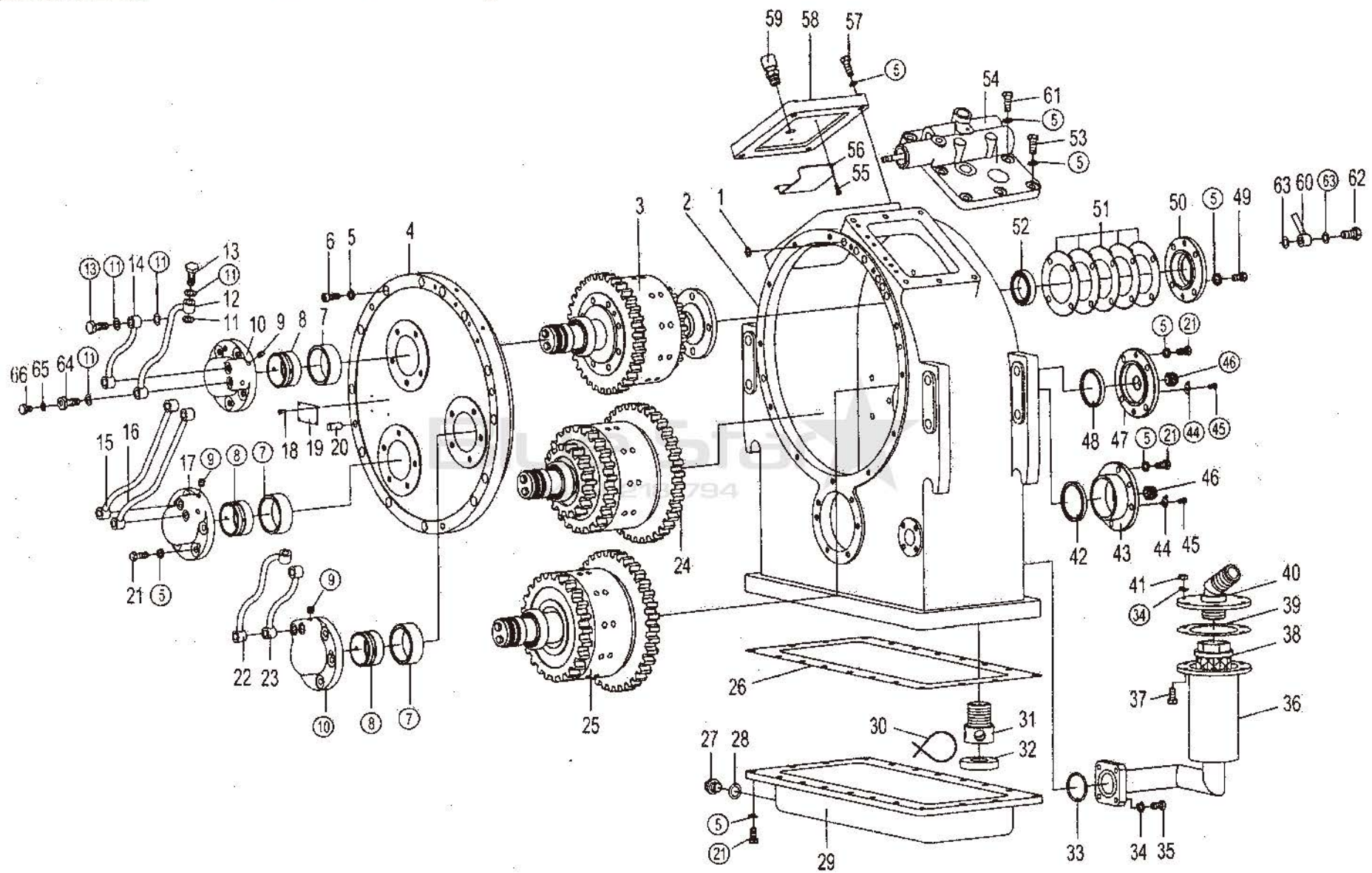

变速箱总成 Transmission Assembly

序号 Ser. No	零件名称 Part Name		数量 Qty	零件代号 Part No
1	0型圈 14x2.65	O ring 14x2.65	6	GB3452.1-82
2	箱体	Housing	1	
3	输入轴总成	Clutch	1	
4	大端盖	Large end cover	1	
5	垫圈 10	Washer 10	90	GB93-87
6	螺钉 M10x30	Screw M10x30	13	GB70-85
7	轴套	Sleeve	3	
8	外封油套	Sleeve	3	
9	螺塞 Z1/8"	Plug Z1/8"	6	Q/ZB223-77
10	输入、倒档轴进油盖	Oil inlet cover input reverse	2	
11	垫圈 A12	Washer A12	24	JB982-77
12	I 档油管	I st gear vitta	1	
13	空心螺栓	Hollow bolt 218 794	11	
14	润滑油管 I	Wbricating vitta I	1	
15	II 档油管	II st gear vitta	1	
16	润滑油管 II	Wbricating vitta II	1	
17	中间轴进油盖	Inlet cover of middle shaft	1	
18	铆钉 2x5	Rivet 2x5	4	GB827-86
19	变速箱标牌	Plate	1	
20	销 B12x40	Pin B12x40	2	GB119-86
21	螺栓 M10x30	Bolt M10x30	30	GB5783-86
22	润滑油管 III	Wbricating vitta III	1	
23	倒档油管	Reveres gear vitta	1	
24	中间轴总成	Clutch	1	

变速箱总成 Transmission Assembly

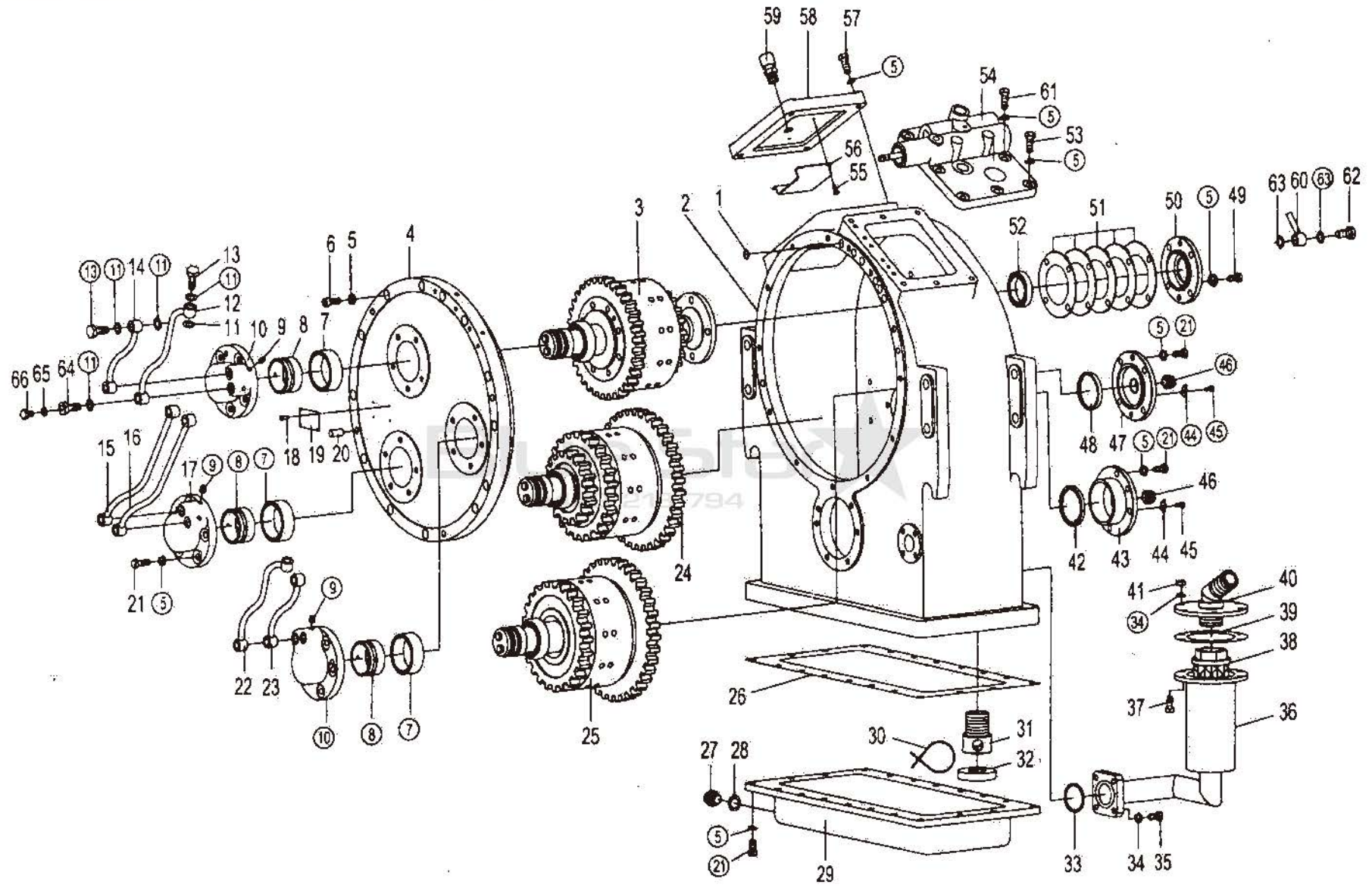

变速箱总成 Transmission Assembly

序号 Ser. No	零件名称 Part Name	数量 Qty	零件代号 Part No
25	倒档轴总成	1	
26	油底壳纸垫	1	
27	螺钉	1	
28	O 型圈 22.4x2.65	1	GB3452.1-82
29	油底壳	1	
30	防松丝 ϕ 2x120	2	
31	吸油管	1	
32	永久磁铁	1	
33	O 型圈 42.5x3.55	1	GB3452.1-82
34	垫圈 8	14	GB93-87
35	螺栓 M8x30	4	GB5783-86
36	接管总成	1	
37	螺栓 M8x25	6	GB5783-86
38	滤芯 WL-100x100-J	1	
39	垫片	1	
40	接头总成	1	
41	螺母 M8	6	GB6170-86
42	中间轴调整环	1	
43	中间轴端盖	1	
44	止动片	2	
45	螺栓 M6x6	2	GB5783-86
46	调整螺丝	2	
47	倒档轴端盖	1	
48	倒档轴调整环	1	

变速箱总成 Transmission Assembly

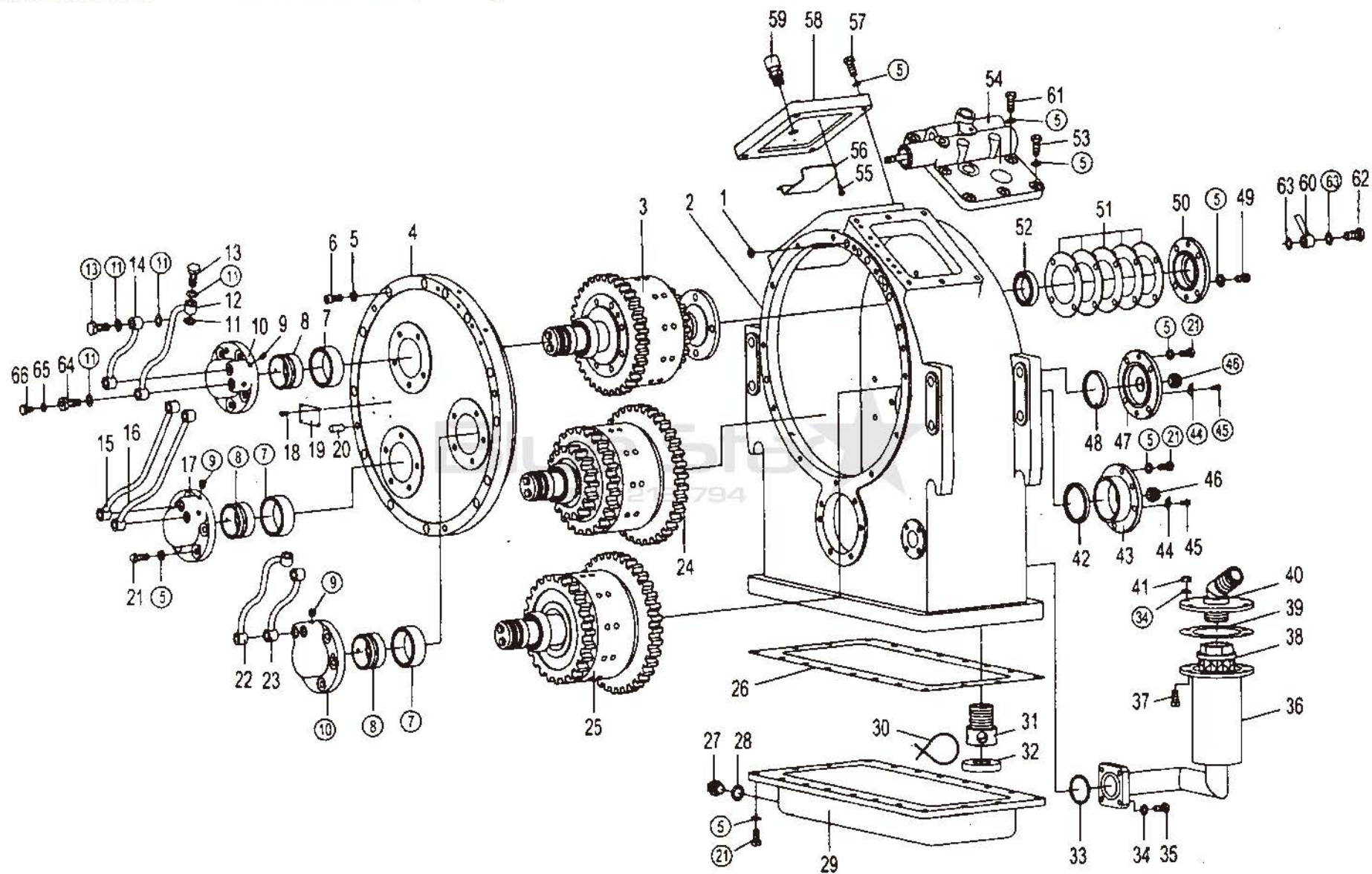

变速箱总成 Transmission Assembly

序号 Ser. No	零件名称 Part Name	数量 Qty	零件代号 Part No	
49	小六角头螺栓	Bolt	4	
50	输入轴端盖	End cover, input shaft	1	
51	输入轴调整垫片 $\delta 0.05$	Shim, input shaft $\delta 0.05$	2	
51	输入轴调整垫片 $\delta 0.1$	Shim, input shaft $\delta 0.1$	2	
	输入轴调整垫片 $\delta 0.2$	Shim, input shaft $\delta 0.2$	2	
	输入轴调整垫片 $\delta 0.3$	Shim, input shaft $\delta 0.3$	1	
51	输入轴调整垫片 $\delta 0.5$	Shim, input shaft $\delta 0.5$	1	
52	油封 PD45x62x12	Oil seal PD45x62x12	1	HG4-692-67
53	螺栓 M10x50	Bolt M10x50	6	GB5783-86
54	变速操纵阀总成	Transmission control valve	1	
55	螺钉 M4x10	Screw M4x10	4	GB67-85
56	挡油盖	Cover	1	
57	螺栓 M10x35	Bolt M10x35	4	GB5783-86
58	变速箱盖	Transmission cover	1	
59	呼吸器总成	Breather assembly	1	
60	M14×1.5 低压软管	Low pressure hose M14×1.5	1	
61	螺栓 M10×55	Bolt M10x55	2	GB5782-86
62	螺栓 M10×1×25	Bolt M10×1×25	1	JB999-77
63	组合垫圈 A10	Washer A10	2	JB982-77
64	清洁度测试螺栓	Bolt	1	
65	螺塞	Plug M10×1	1	JB/ZQ4450-97
66	垫圈	Washer 10	1	JB1002-77

输入轴总成 (I, III) Input Shaft Assembly

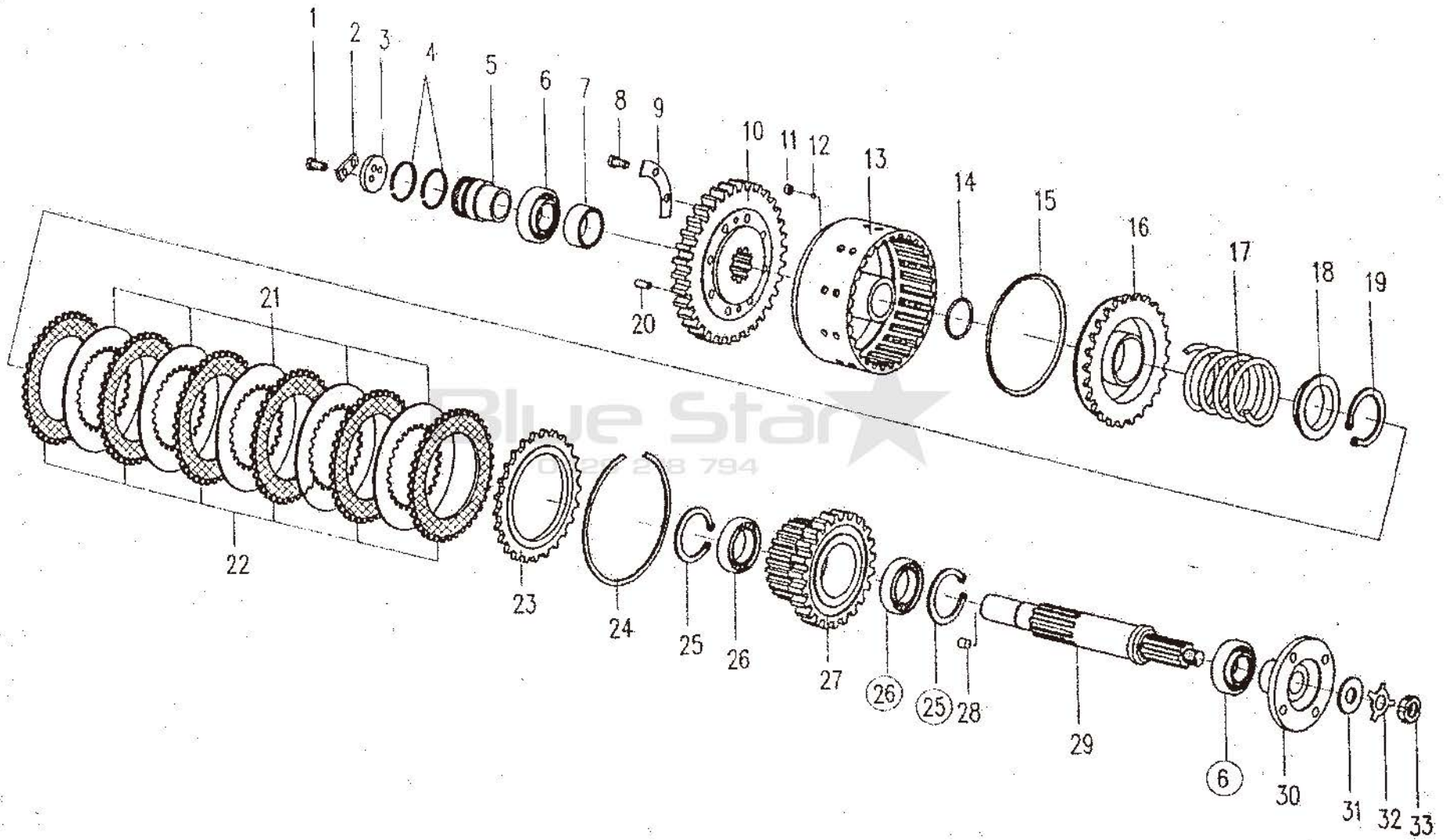

输入轴总成 Input Shaft Assembly

序号 Ser. No	零件名称 Part Name		数量 Qty	零件代号 Part No
1	螺栓 M8x16	Bolt M8x16	2	GB5783-86
2	止动垫	Lock plate	1	
3	轴端挡板	Apron	1	
4	活塞环	Piston seal ring	2	GB297-84
5	内封油套	Stud sleeve	1	
6	轴承 7507E	Bearing 7507E	2	
7	输入轴轴套	Sleeve	1	GB5783-86
8	螺栓 M10x25	Bolt M10x25	8	
9	锁止片	Lock skim Plug	1	
10	输入轴 2、4 档齿轮	2 nd , 4 th speed gear	1	GB308-89
11	球座	Ball seat	1	
12	钢球 φ5	Steel ball φ5	1	
13	齿圈总成	Gear ring seat	1	GB3452.1-82
14	O 型圈 53x3.55	O ring 53×3.55	1	
15	活塞外封环	Piston output seal ring	1	
16	活塞	Piston	1	
17	弹簧	Spring	1	
18	弹簧座	Spring retainer	1	
19	挡圈 60	Snap ring 60	1	GB894.1-86
20	销 A8x22	Pin A8x22	2	GB119-86
21	内摩擦片	Driven disc	5	
22	外摩擦片	Driven disc	6	
23	外端盘	Output end disc	1	
24	挡圈	Snap ring	1	

输入轴总成 Input Shaft Assembly

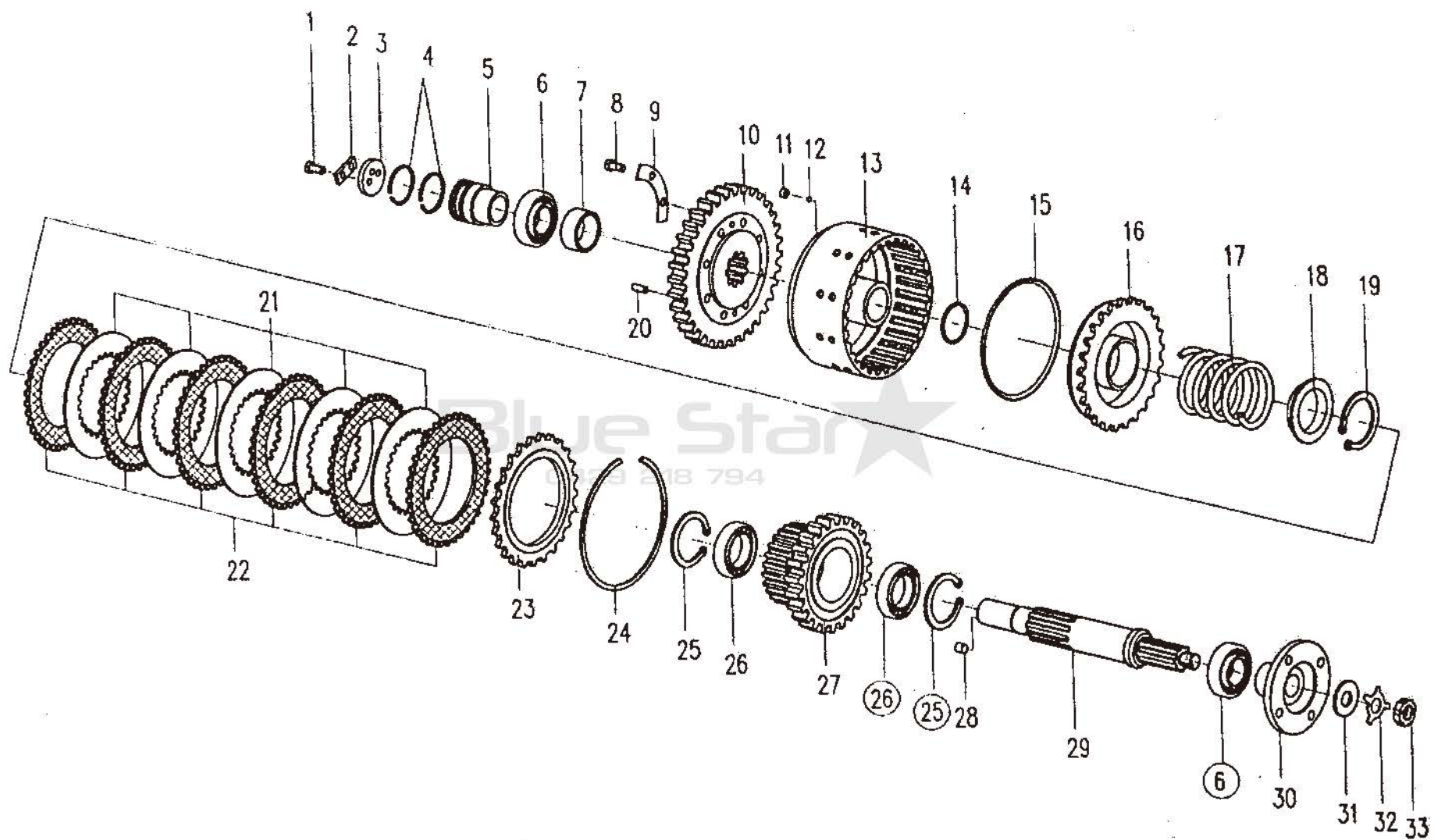

输入轴总成 Input Shaft Assembly

序号 Ser. No	零件名称 Part Name		数量 Qty	零件代号 Part No
25	挡圈 75	Snap ring 75	2	GB893.1-86
26	轴承 109	Bearing 109	2	GB276-89
27	输入轴 1、3 档齿轮	1 st , 3 rd speed gear	1	
28	闷塞	Plug	1	
29	输入轴	Input shaft	1	
30	输入法兰总成	Input shaft flange	1	
31	输入轴压板	Input shaft set plate	1	
32	垫圈 20	Washer 20	1	
33	螺母 M20x1.5	Nut M20 x1.5	1	



注：序号 10 和 13 必须配对使用。

倒档轴总成 Reverse Gear Shift Assembly

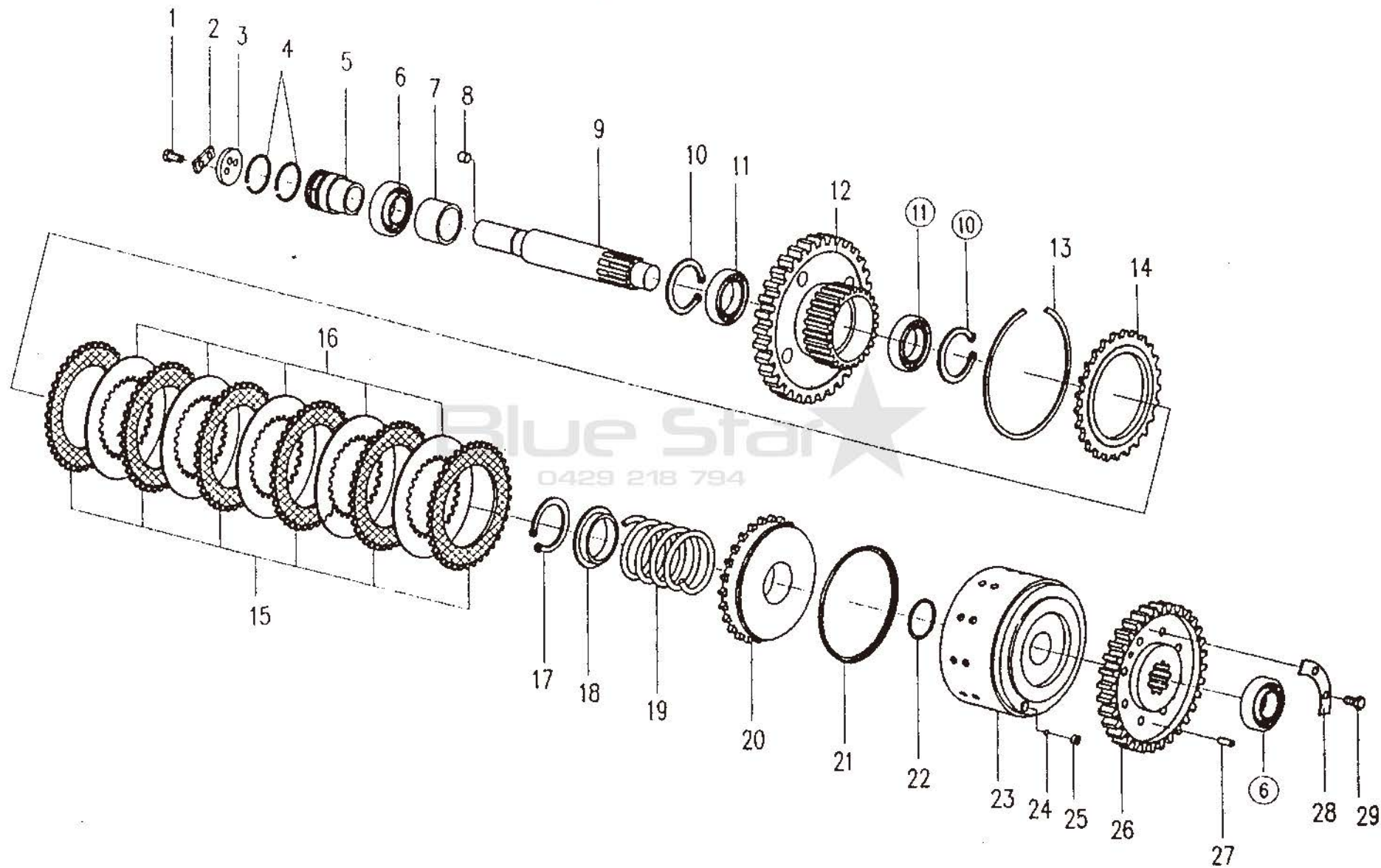

倒档轴总成 Reverse Gear Shift Assembly

序号 No.	零件名称 Part Name	数量 Qty	零件代号 Part No
1	螺栓 M8x16	2	GB5783-86
2	止动垫	1	
3	轴端挡板	1	
4	活塞环	2	GB297-84
5	内封油套	1	
6	轴承 7507E	2	
7	倒档轴轴套	1	
8	闷塞	1	
9	倒档轴	1	
10	挡圈 75	2	GB893.1-86
11	轴承 109	2	GB276-89
12	倒档轴大齿轮	1	
13	挡圈	1	
14	外端盘	1	
15	外摩擦片	6	
16	内摩擦片	5	GB894.1-86
17	挡圈 60	1	
18	弹簧座	1	
19	弹簧	1	
20	活塞	1	
21	活塞外封环	1	
22	O型圈 53x3.55	1	GB3452.1-82
23	齿圈总成	1	GB308-89
24	钢球 $\phi 5$	1	

倒档轴总成 Reverse Gear Shift Assembly

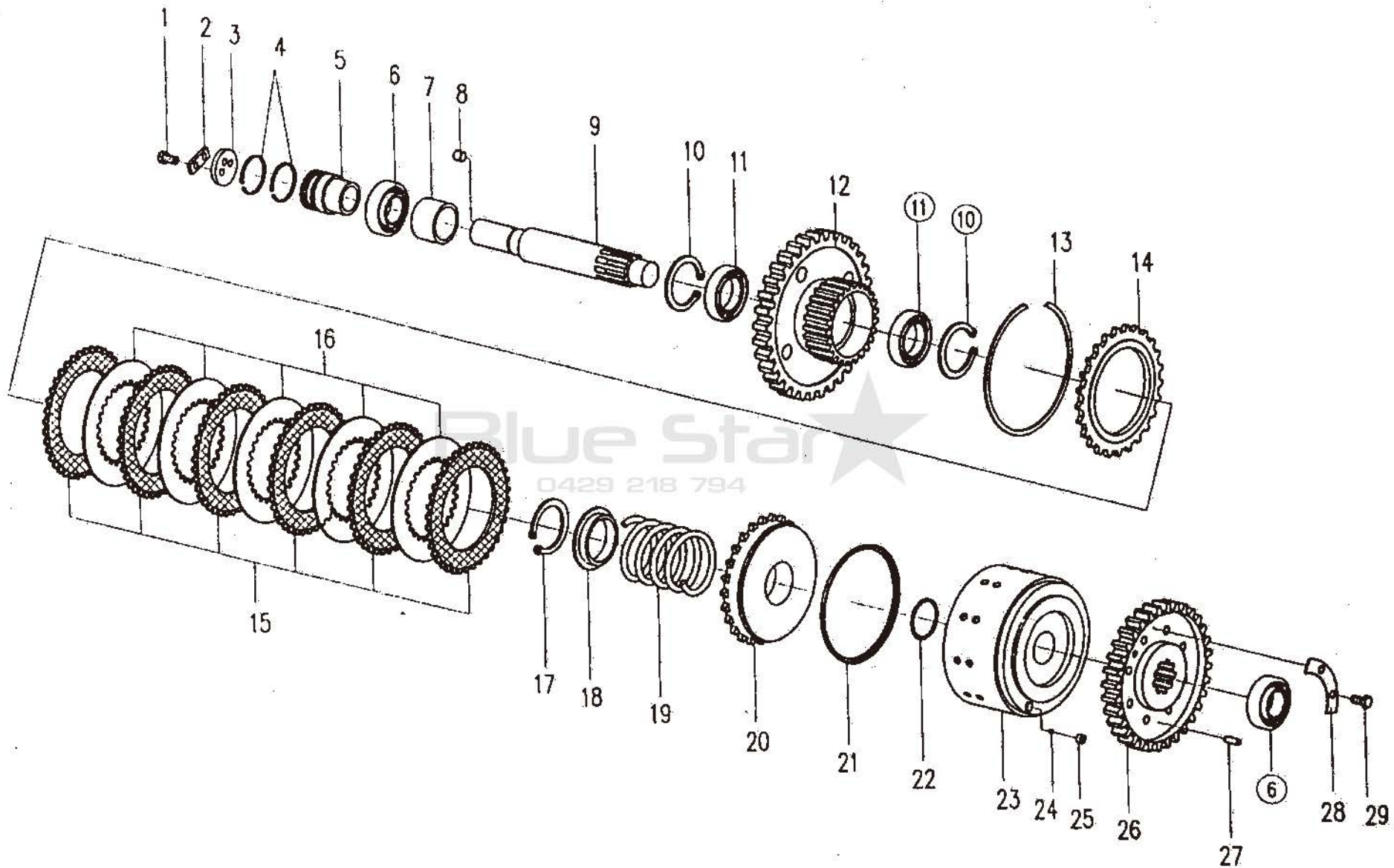

倒档轴总成 Reverse Gear Shift Assembly

序号 No.	零件名称 Part Name	数量 Qty	零件代号 Part No
25	球座 BALL SEAT	1	
26	倒档轴小齿轮 PINION REVERSE SHAFT	1	
27	销 A8x22 PIN A8x22	2	GB119-86
28	锁止片 LOCK SKIM	4	
29	螺栓 M10x25 BOLT M10x25	8	GB5783-86

注：序号 23 和 26 必须配对使用。

中间轴总成 Clutch Shift

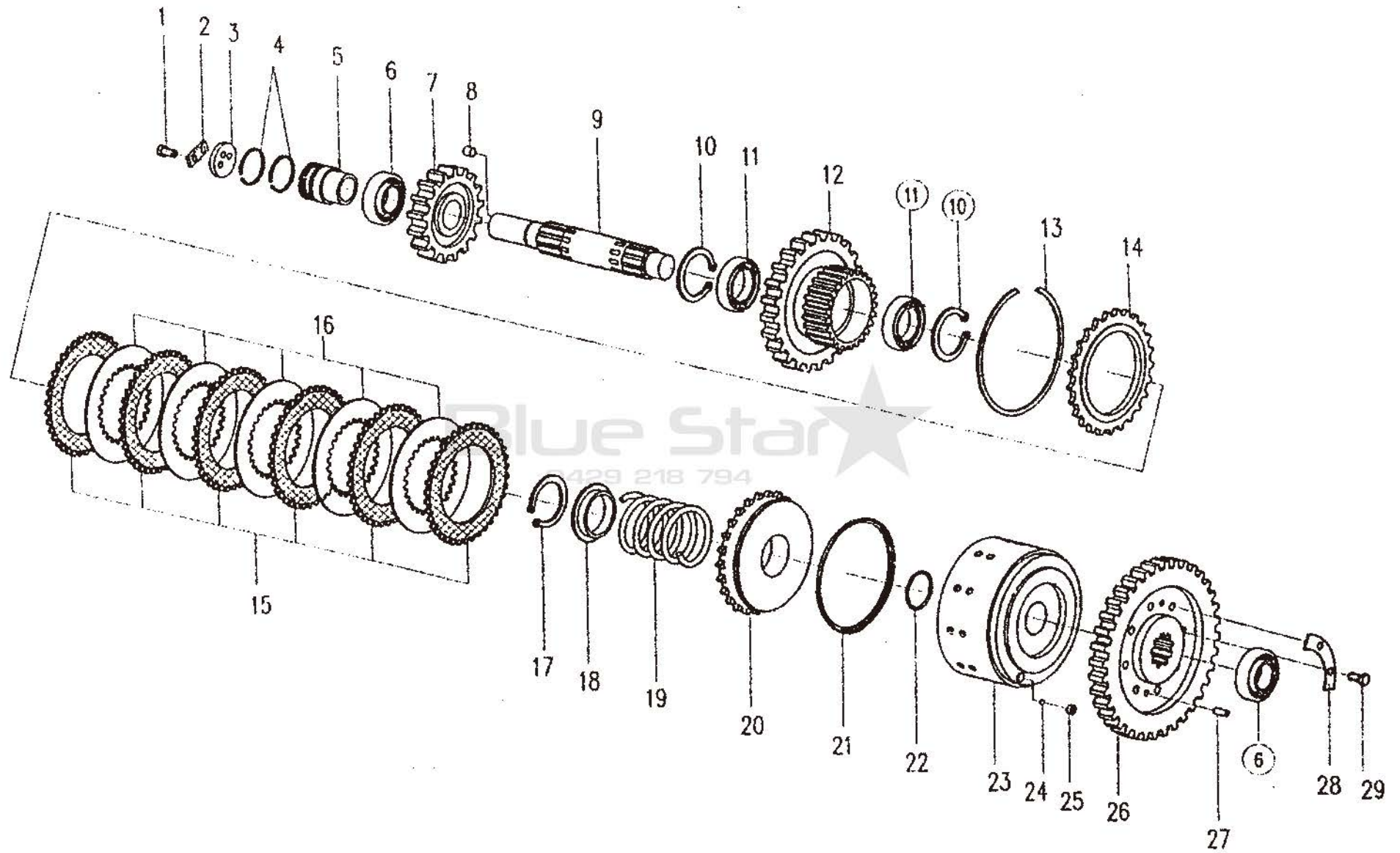

中间轴总成 Clutch Shift

序号 No.	零件名称 Part Name		数量 Qty	零件代号 Part No
1	螺栓 M8x16	BOLT M8x16	2	GB5783-86
2	止动垫	LOCK PLATE	1	
3	轴端挡板	APRON	1	
4	活塞环	PISEON SEAL RING	2	GB297-84
5	内封油套	STUD SLEEVE	1	
6	轴承 7507E	BEARING 7507E	2	
7	中间轴低档齿轮	LOW SPEED GEAR	1	
8	闷塞	PLUG	1	
9	中间轴	MIND DRIVING GEAR SHAFT	1	
10	挡圈 75	SNAP RING 75	2	GB893.1-86
11	轴承 109	BEARING 109	2	GB276-89
12	中间轴 II、IV 档齿轮	2nd, 4rd SPEED GEAR	1	
13	挡圈	SNAP RING	1	
14	外端盘	OUTPUT END DISC	1	
15	外摩擦片	DRIVEN DISC	6	
16	内摩擦片	Driven disc	5	GB894.1-86
17	挡圈 60	SNAP RING 60	1	
18	弹簧座	SPRING RETAINER	1	
19	弹簧	SPRING	1	
20	活塞	PISTON	1	
21	活塞外封环	PISTON OUTPOT SEAL RING	1	
22	O 型圈 53x3.55	O RING 53x3.55	1	GB3452.1-82
23	齿圈总成	GEAR RING SEAT	1	GB308-89
24	钢球 $\phi 5$	STEEL BALL $\phi 5$	1	

中间轴总成 Clutch Shift

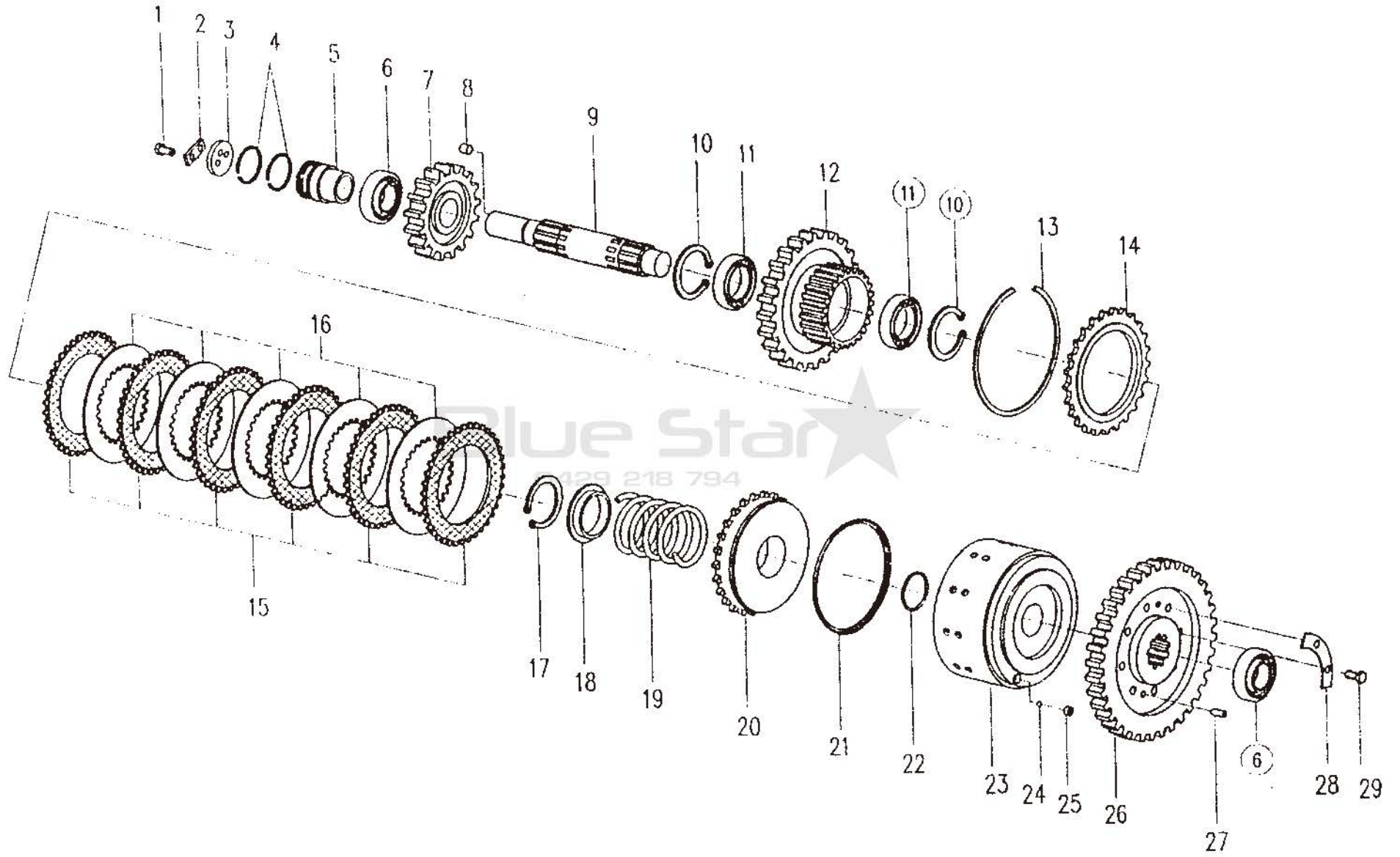

中间轴总成 Clutch Shift

序号 No.	零件名称 Part Name		数量 Qty	零件代号 Part No
25	球座	BALL SEAT	1	
26	中间轴 I、III档齿轮	1st, 3rd SPEED GEAR	1	
27	销 A8x22	PIN A8x22	2	GB119-86
28	锁止片	LOCK SKIM	4	
29	螺栓 M10x25	BOLT M10x25	8	GB5783-86
			0	



注：序号 23 和 26 必须配对使用。

输出轴总成 Output Shift Assembly

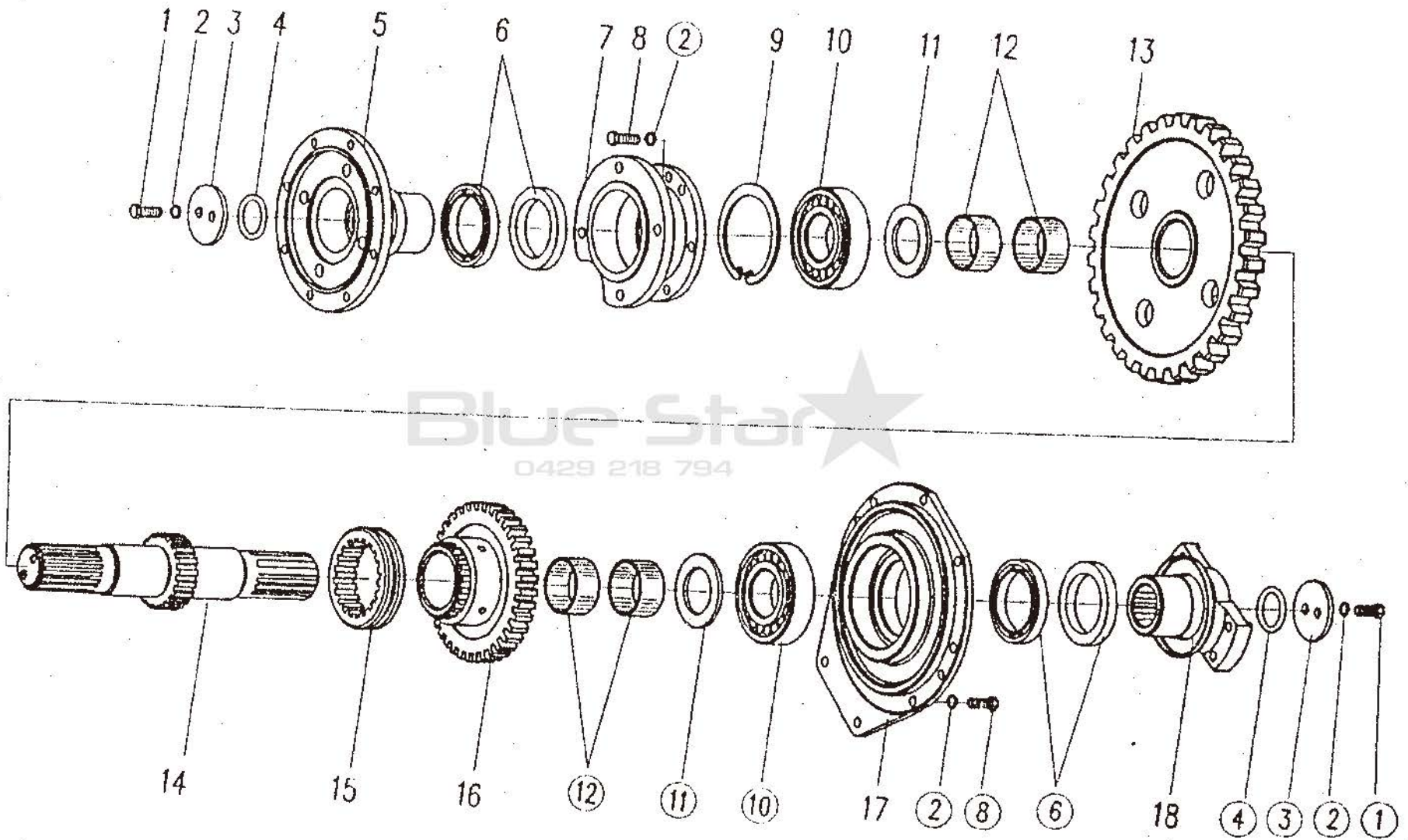

输出轴总成 Output Shift Assembly

序号 Ser. No	零件名称 Part Name	数量 Qty	零件代号 Part No
1	螺栓 M10x25-10.9	4	GB5783-86
2	垫圈 10	18	GB93-87
3	压板	2	
4	O型圈	2	
5	变速箱前输出法兰	1	
6	油封 SG65x90x12	4	HG4-692-67
7	输出轴前端盖	1	
8	螺栓 M10x30	14	GB5783-86
9	挡圈 90	1	GB893.1-86
10	轴承 310	2	GB276-89
11	止推环	2	
12	输出轴轴套	4	
13	输出轴低档齿轮	1	
14	输出轴	1	
15	高低档滑动齿套	1	
16	输出轴高档齿轮	1	
17	输出轴后端盖	1	
18	后输出法兰总成	1	

高低档拨叉机构 Shift Yoke Mechanism

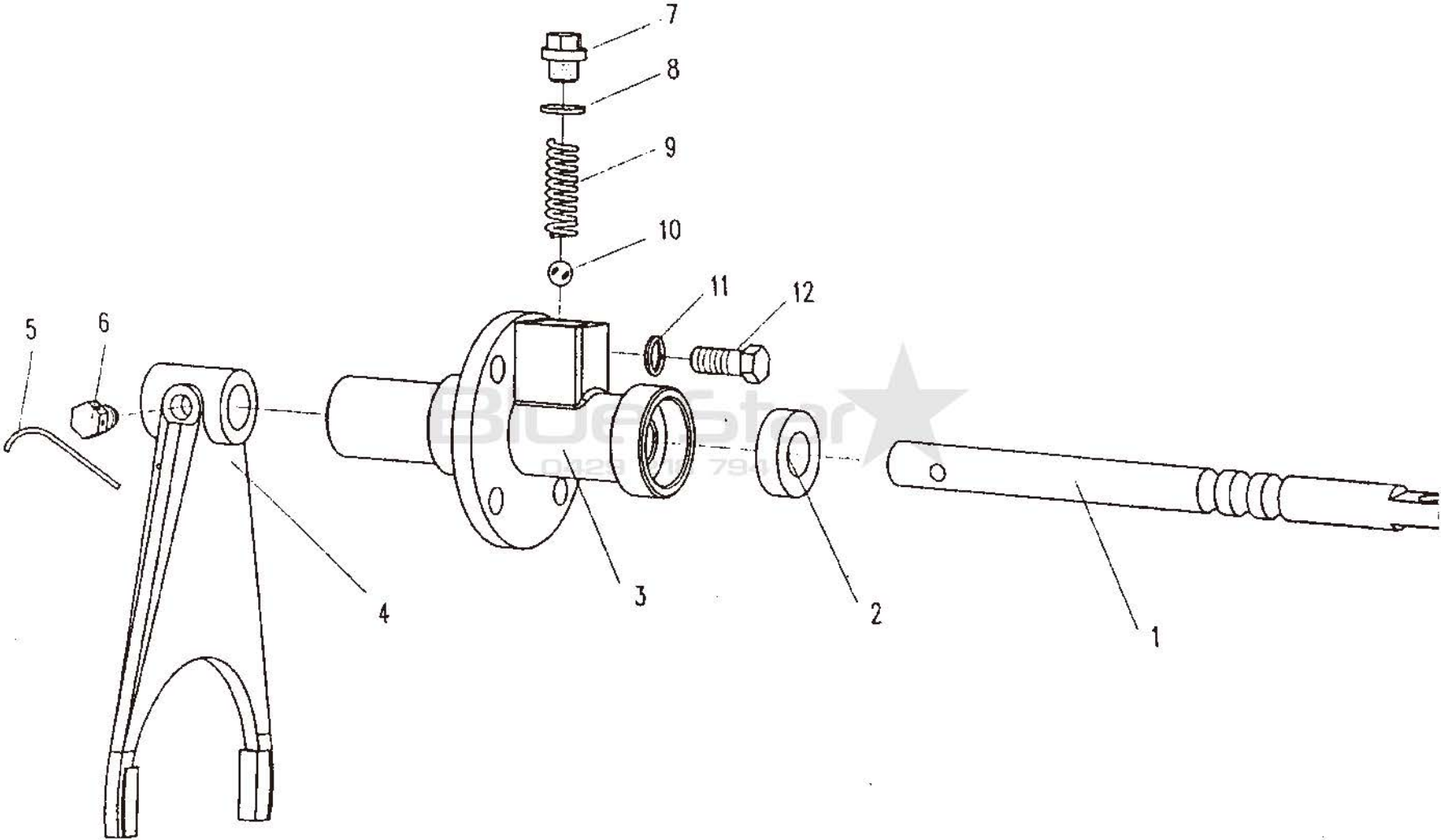

高低档拨叉机构 Shift Yoke Mechanism

序号 Ser. No	零件名称 Part Name		数量 Qty	零件代号 Part No
1	拨叉轴	Yoke shaft	1	
2	油封 FB18x35x10	Oil seal FB18x35x10	1	GB13871-92
3	拨叉支架	Yoke seat	1	
4	换档拨叉	Yoke	1	
5	防松丝 $\phi 1 \times 100$	Slack wire $\phi 1 \times 100$	1	
6	紧定螺钉	Screw	1	
7	螺钉	Screw	1	
8	垫圈	Lock washer	1	
9	弹簧	Spring	1	
10	钢球 $\phi 10$	Steel ball $\phi 10$	1	GB308-86
11	垫圈 10	Lock washer 10	4	GB93-87
12	螺栓 M10x25	Bolt M10x25	4	GB5783-86
		0429 218 794		

变速箱操纵阀总成 Transmission Control Valve

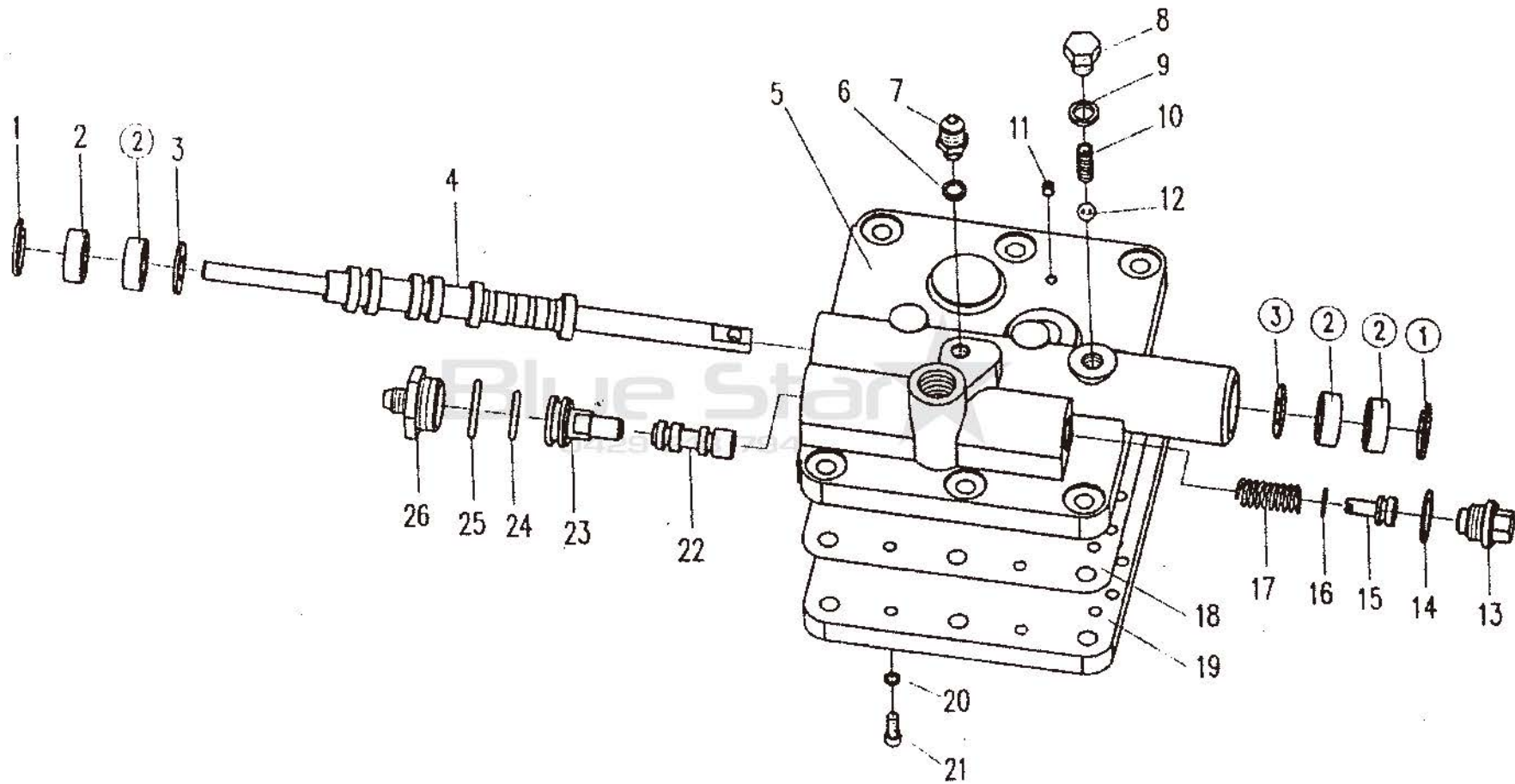

变速箱操纵阀总成 Transmission Control Valve

序号 Ser. No	零件名称 Part Name		数量 Qty	零件代号 Part No
1	挡圈 30	Snap Ring 30	2	GB893.1-86
2	油封 PD14x30x10	Seal PD14x30x10	4	HG4-692-67
3	垫圈	Washer	2	
4	操纵滑阀总成	Valve spool	1	
5	阀体	Block	1	
6	垫圈 10	Washer 10	1	JB1002-77
7	测压接头	Load cell joint	1	
8	螺钉	Screw	1	
9	垫圈 12	Washer 12	1	JB1002-77
10	弹簧	Spring	1	
11	螺塞 Z1/8"	Thread plug Z1/8"	1	Q/ZB223-77
12	钢球 $\phi 10$	Steel ball $\phi 10$	1	GB308-89
13	螺塞	Thread plug	1	
14	垫圈	Washer	1	
15	弹簧座	Retainer	1	
16	O型圈 11.2x2.65	O-ring 11.2x2.65	1	GB3452.1-82
17	弹簧	Spring	1	
18	垫片	Spacer	1	
19	底板	Soleplate	1	
20	垫圈 6	Washer 6	15	GB93-87
21	螺钉 M6x16	Screw M6x16	15	GB70-85
22	制动滑阀	Brake slide valve	1	
23	气阀杆	Air valve stem	1	
24	O型圈 22.4x3.55	O-ring 22.4x3.55	1	GB3452.1-82
25	O型圈 26.5x3.55	O-ring 26.5x3.55	1	GB3452.1-82
26	进气接头	Connector	1	

前后桥总成 Front/Rear axle assembly

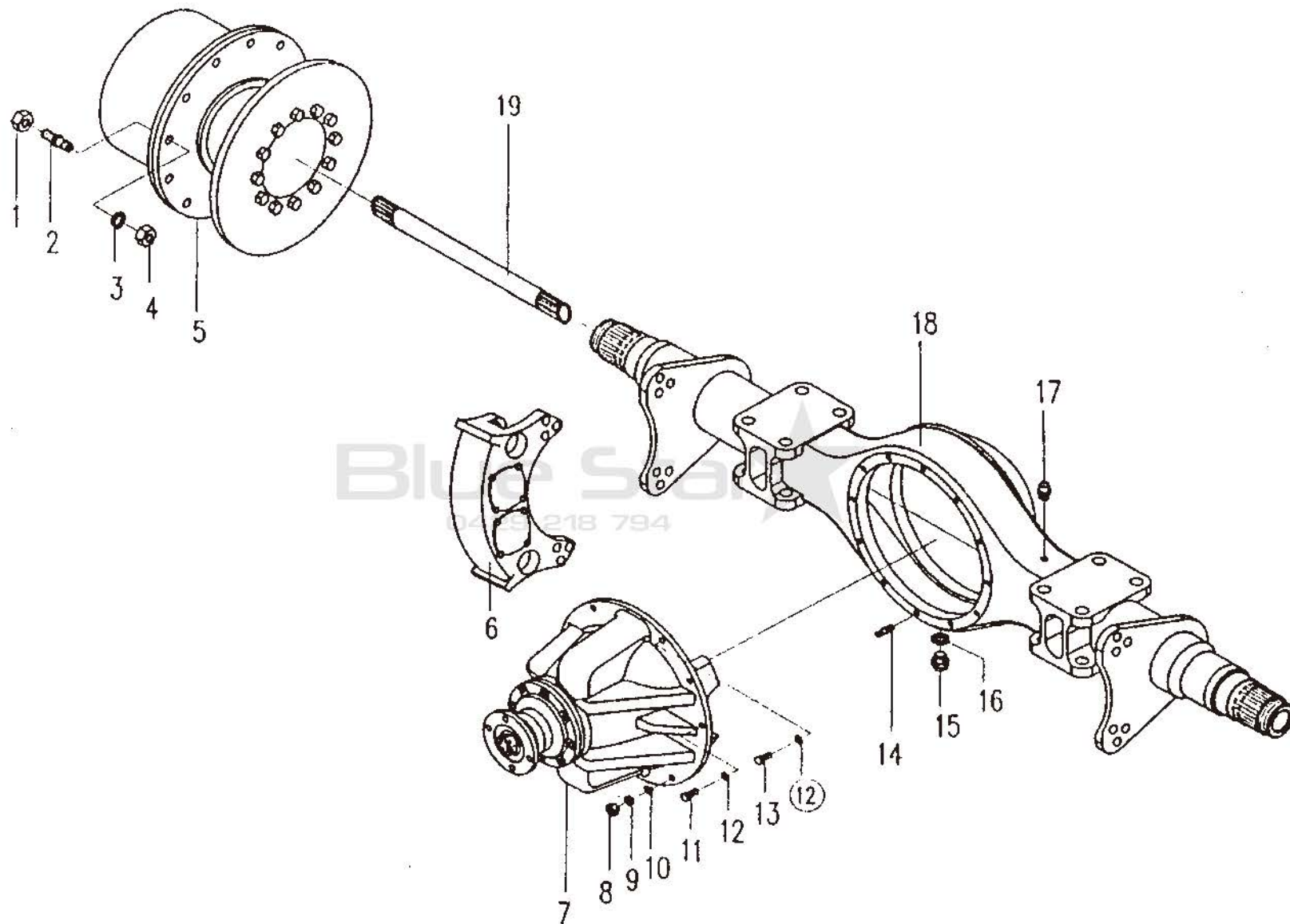

前后桥总成 Front/Rear axle assembly

序号 Ser. No	零件名称 Part Name		数量 Qty	零件代号 Part No
1	轮辋螺母(左、右旋各半)	Nut	24	79600119
2	轮辋螺栓(左、右旋各半)	Rim bolt	24	80240003
3	垫圈 20	Washer 20	24	52020008
4	螺母 M20×1.5	Nut M20×1.5	24	51010007
5	轮边减速器总成	Wheel-end-reducer assembly	2	83240200
6	制动器总成	Pliers assembly	2	72006035
7	主减速器总成	Main reducer assembly	1	82350200
8	螺母 M10	Nut M10	3	51014003
9	垫圈 10	Washer10	3	52000002
10	固定锥套	Fixed cone	3	75500681
11	螺栓 M10×30	Bolt M10×30	7	75500151
12	垫圈 10	Washer10	11	52020003
13	螺栓 M10×40	Bolt M10×40	4	75500159
14	螺柱 M10×50	Double-screw bolt M10×50	3	75500225
15	螺塞 M24×1.5	Thread plug M24×1.5	2	75500197
16	组合密封垫圈	Compound seal	2	53200005
17	通气塞	Air bleed valve	1	56100001
18	桥壳总成	Housing assembly	1	80350100
19	半轴	Axle shaft	2	80214001
注:	主减速器总成(后桥)	Main reducer assembly	1	
	从动螺旋伞齿轮(后桥)	Spiral bevel driving gear	1	
	主动螺旋伞齿轮(后桥)	Spiral bevel driving gear	1	
	桥壳(后桥)	Housing assembly	1	
	主减油封 60×80×8	Oil seal60×80×8	1	

主减速器总成 Main reducer assembly

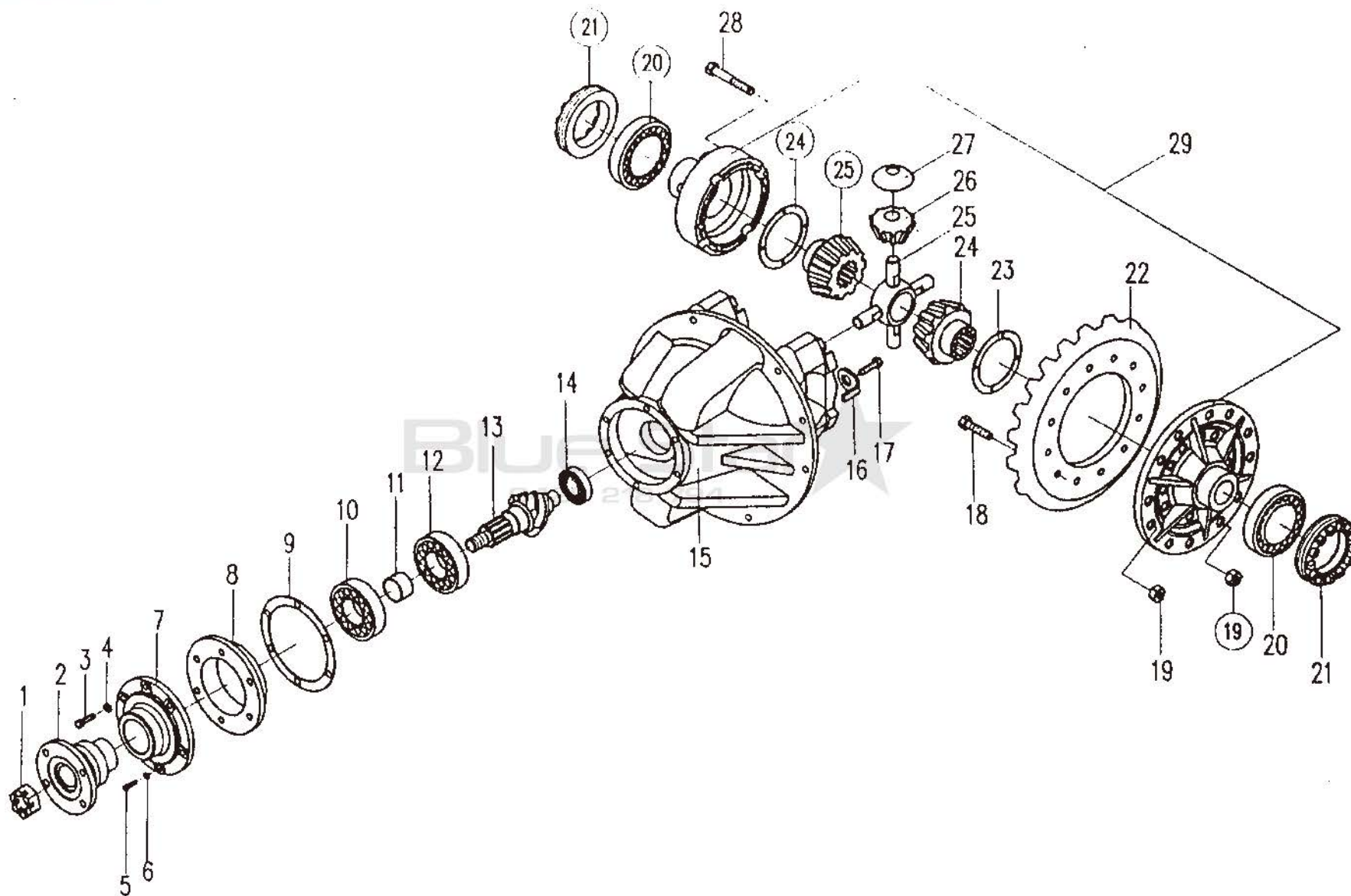

主减速器总成 Main reducer assembly

序号 Ser. No	零件名称 Part Name		数量 Qty	零件代号 Part No
1	锁紧螺母	Lock Nut	1	75500013
2	连接法兰组件	Flange assembly	1	82350201
3	螺栓 M14×1.5×45	Bolt M14×1.5×45	5	75500005
4	垫圈 14	Washer 14	5	52020005
5	螺栓 M12×1.5×45	Bolt M12×1.5×45	1	75500006
6	垫圈 12	Washer 12	1	52020004
7	盖总成	Cage assembly	1	75203628
8	轴承座	Bearing cage	1	82214206
9	垫片	Washer	1 组	75200067
10	轴承 27309E	Bearing 27309E	1	54100011
11	隔套	Sleeve	1	82214205
12	轴承 27310E	Bearing 27310E	1	54100012
13	主动螺旋伞齿轮	Spiral bevel driving gear	1	82214203
14	轴承 102306	Bearing 102306	1	54000001
15	主减速器壳体组件	Main reducer case	1	79800023
16	锁紧片	Lock plate	2	75200054
17	螺栓 M10×20	Bolt M10×20	2	50004003
18	螺栓 M12×1.25×50	Bolt M12×1.25×50	12	75500010
19	螺栓 M12×1.25	Bolt M12×1.25	20	51040002
20	轴承 7814E	Bearing 7814E	2	54100038
21	调整螺母	Adjusting nut	2	75200100
22	从动螺旋伞齿轮	Spiral bevel driving gear	1	82215101
23	半轴齿轮垫片	Axle shaft gear washer	2	75201604
24	半轴齿轮	Axle shaft gear	2	75201288

主减速器总成 Main reducer assembly

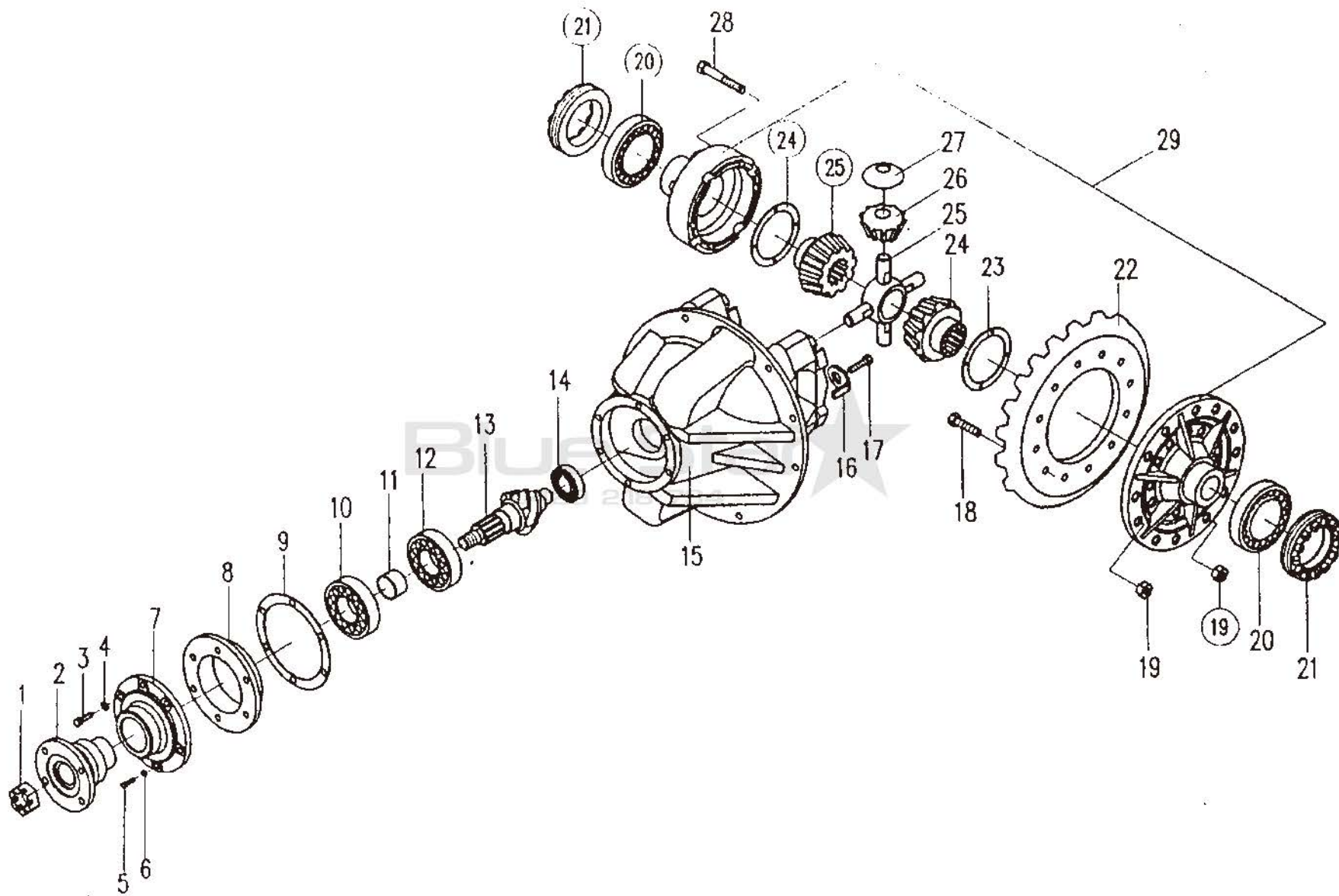

主减速器总成 Main reducer assembly

序号 Ser. No	零件名称 Part Name		数量 Qty	零件代号 Part No
25	十字轴	Cardan shaft	1	75200088
26	行星轮	Planet gear	4	75201289
27	行星齿轮垫片	Planet gear washer	4	75201605
28	凸缘螺栓 M8×12	Flange bolt	8	75501979
29	差速器总成	Differential case assembly	1	79800005



轮边减速器总成 Wheel-end-reducer assembly

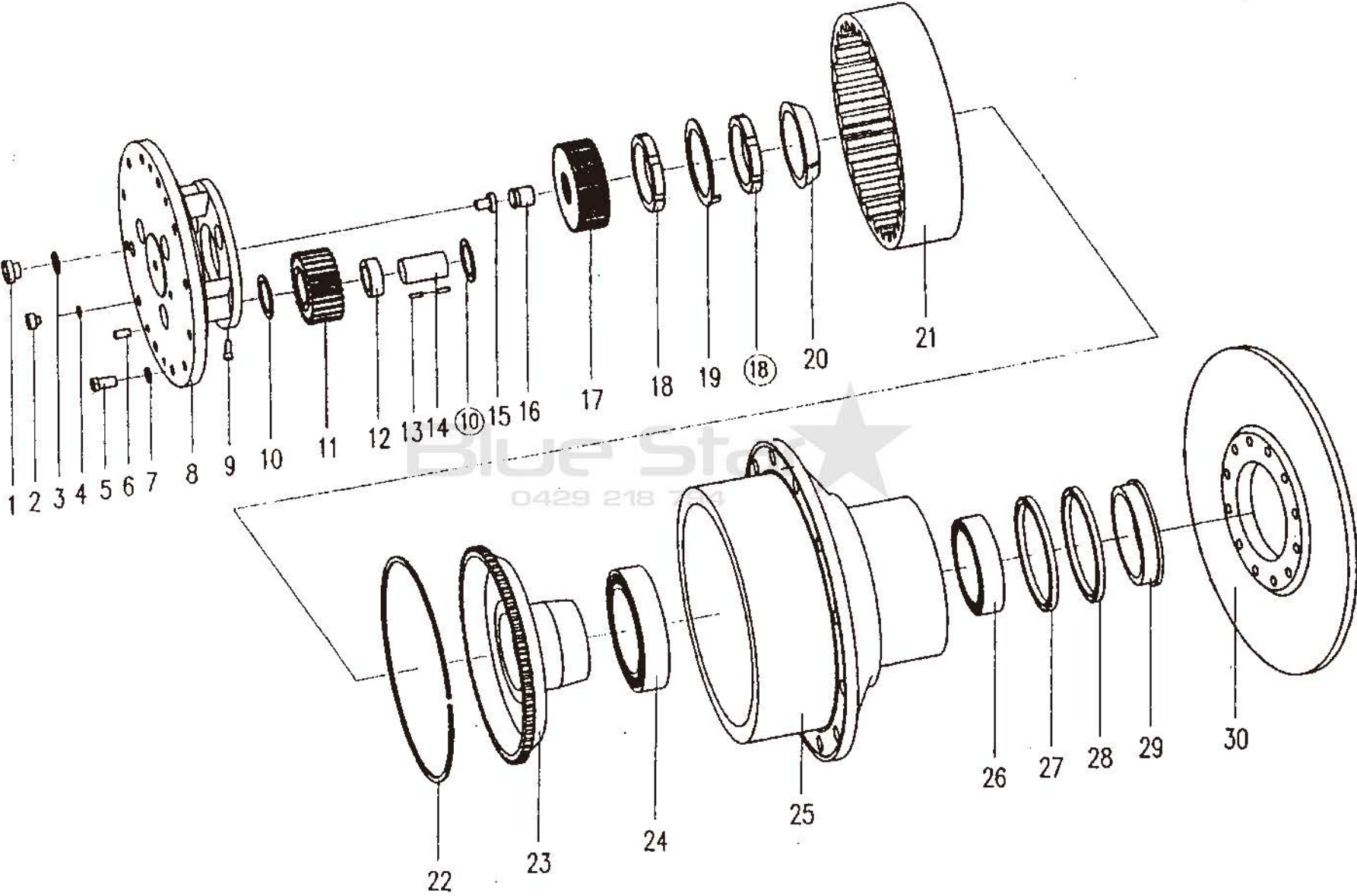

轮边减速器总成 Wheel-end-reducer assembly

序号 Ser. No	零件名称 Part Name		数量 Qty	零件代号 Part No
1	油塞 M24×1.5	Plug M24×1.5	1	75500197
2	螺塞 M12×1.25×9	Thread plug M12×1.25×9	1	75500842
3	组合密封垫圈	Compound seal	1	53200005
4	组合密封垫圈	Compound seal	1	53200002
5	螺栓 M16×1.5×30	Bolt M16×1.5×30	12	50012035
6	销 B12×24	Pin B12×24	2	51270006
7	垫圈 16	Washer 16	12	52020006
8	行星轮架	Planet gear spider	1	83240201
9	螺钉 M8×15	Screw M8×15	3	50160003
10	行星轮垫片	Planet gear washer	6	83240211
11	行星轮	Planet gear	3	83240204
12	隔套	Sleeve	3	
13	滚针	Roll	126	54400006
14	行星轮轴	Planet gear pin	3	83240205
15	限位块	Block	4	83240206
16	调整支柱	Adjusting support	1	77000044
17	太阳轮	Sun gear	1	83240203
18	螺母 M75×2	Nut M75×2	2	71270231
19	锁紧垫片	Lock washer	1	52060005
20	锥套	Sleeve	1	77000021
21	齿圈	Gear ring	1	82340208
22	卡环	Lock ring	1	82340210
23	齿圈支撑	Gear ring support	1	83240209
24	轴承 2007124E	Bearing 2007124E	1	54100006

轮边减速器总成 Wheel-end-reducer assembly

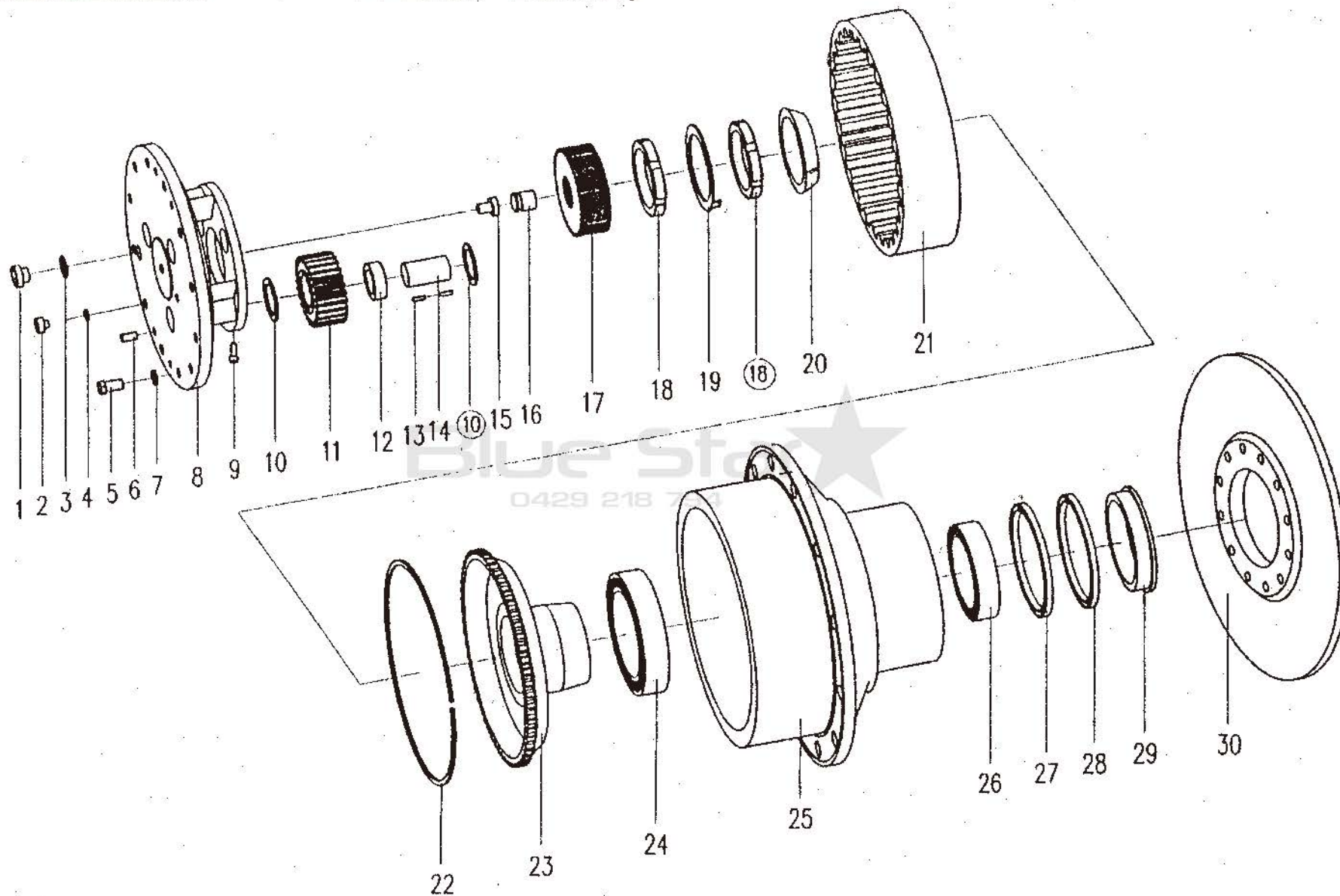

轮边减速器总成 Wheel-end-reducer assembly

序号 Ser. No	零件名称 Part Name		数量 Qty	零件代号 Part No
25	轮毂	Hub	1	83240202
26	轴承 2007122E	Bearing 2007122E	1	54100005
27	油封 B140×170×15	Oil seal B140×170×15	1	53100013
28	油封 FB140×170×15	Oil seal FB140×170×15	1	53100005
29	油封座	Oil seal cage	1	83021509
30	制动盘	Brake disc	1	



制动器总成 Pliers assembly

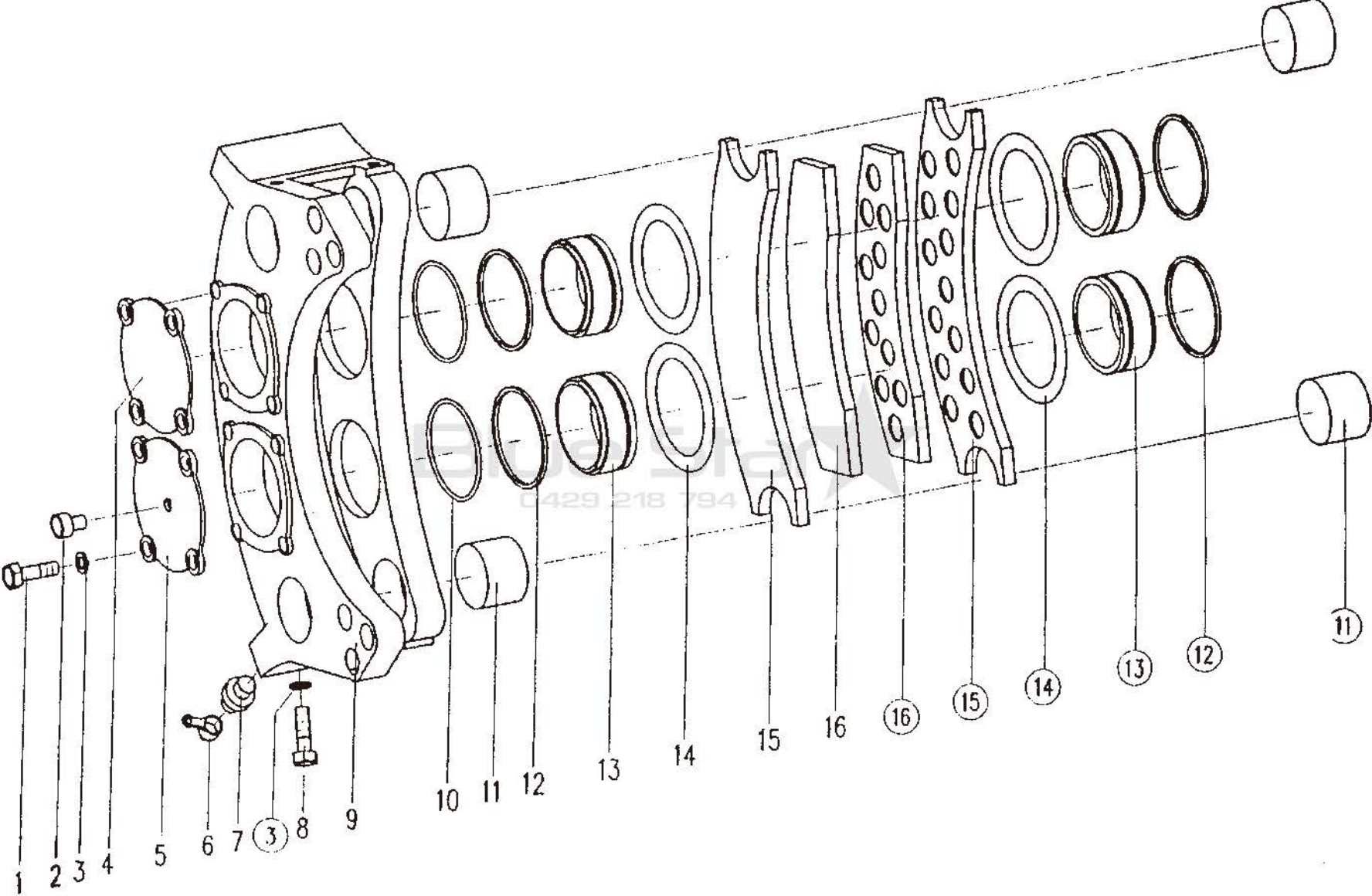

制动器总成 Pliers assembly

序号 Ser. No	零件名称 Part Name		数量 Qty	零件代号 Part No
1	螺栓 M10×35	Bolt M10×35	8	50009015
2	孔塞	Plug	1	75700459
3	垫圈 10	Washer 10	12	52020003
4	封油分泵盖	Cover	1	75700443
5	进油分泵盖	Cover	1	75700458
6	放气嘴保护罩	Air bleed valve protect cover	2	55400001
7	放气嘴	Air bleed valve	2	75700042
8	螺栓 M10×35	Bolt M10×35	4	51014003
9	夹钳体	Clamp body	1	75700436
10	O型密封圈 75×3.1	O-ring 75×3.1	2	53000010
11	销轴	Pin	4	75700437
12	矩形密封圈	Rectangle pressurize ring	4	75700439
13	活塞	Piston	4	75700440
14	防尘圈	Dustproof ring	4	75700438
15	摩擦垫块底板	Friction slice soleplate	4	75700435
16	摩擦片	Friction slice	4	75700463

变速箱支架总成 Transmission Bracket assembly

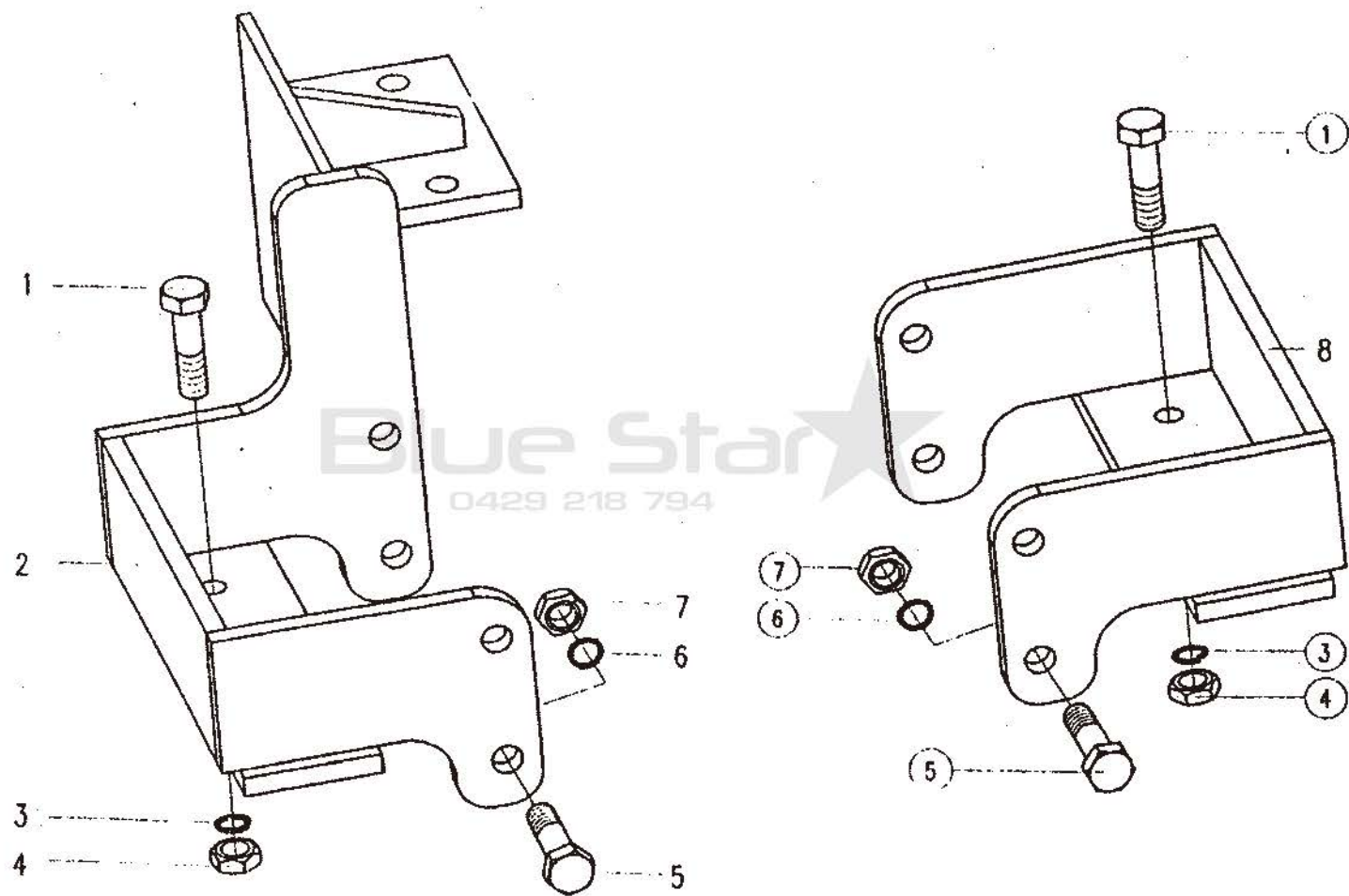

变速箱支架总成 Transmission Bracket assembly

序号 Ser. No	零件名称 Part Name		数量 Qty	零件代号 Part No
1	螺栓 M14×55	Bolt M14x55	4	GB5782-86
2	变速箱左支架	Transmission Left Bracket	1	
3	垫圈 14	Washer 14	4	GB93-87
4	螺母 M14	Nut M14	4	GB6170-86
5	螺栓 M16×80	Bolt M16x80	8	GB5782-86
6	垫圈 16	Washer 16	8	GB93-87
7	螺母 M16	Nut M16	8	GB6170-86
8	变速箱右支架	Transmission Right Bracket	1	



轮辋总成 Rim Assembly

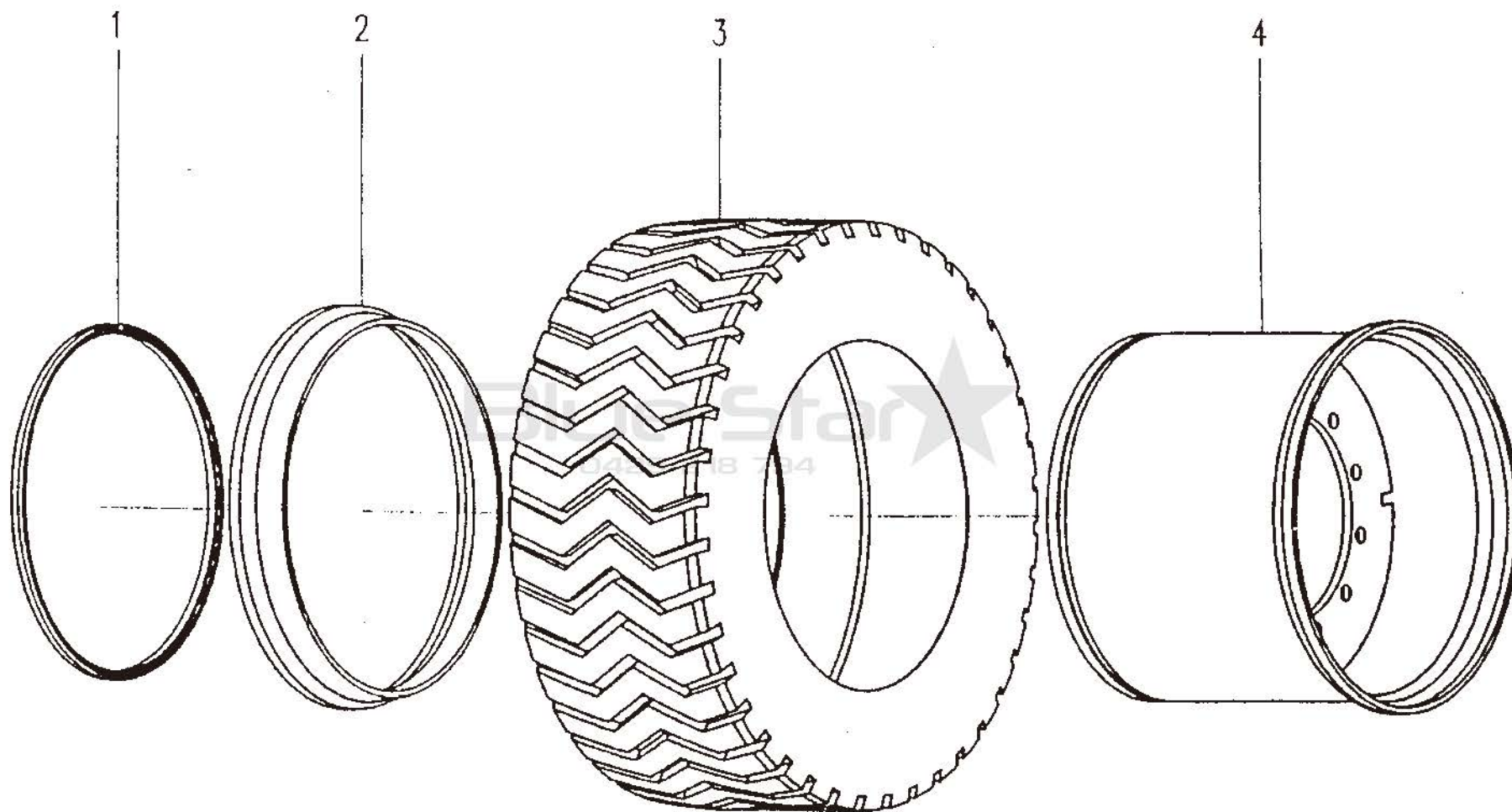

轮辋总成 Rim Assembly

序号 Ser. No	零件名称 Part Name		数量 Qty	零件代号 Part No
1	锁圈	Lock ring	4	
2	外挡圈	Outer snap ring	4	
3	轮胎 17.5-25	Tyre 17.5-25	4	
4	轮辋 14.00/1.5-2.5	Rim 14.00/1.5-2.5	4	GB2883-93
	轮辋总成 (1, 2, 4 组成)	Rim Assembly	4	



制动系统 Brake System

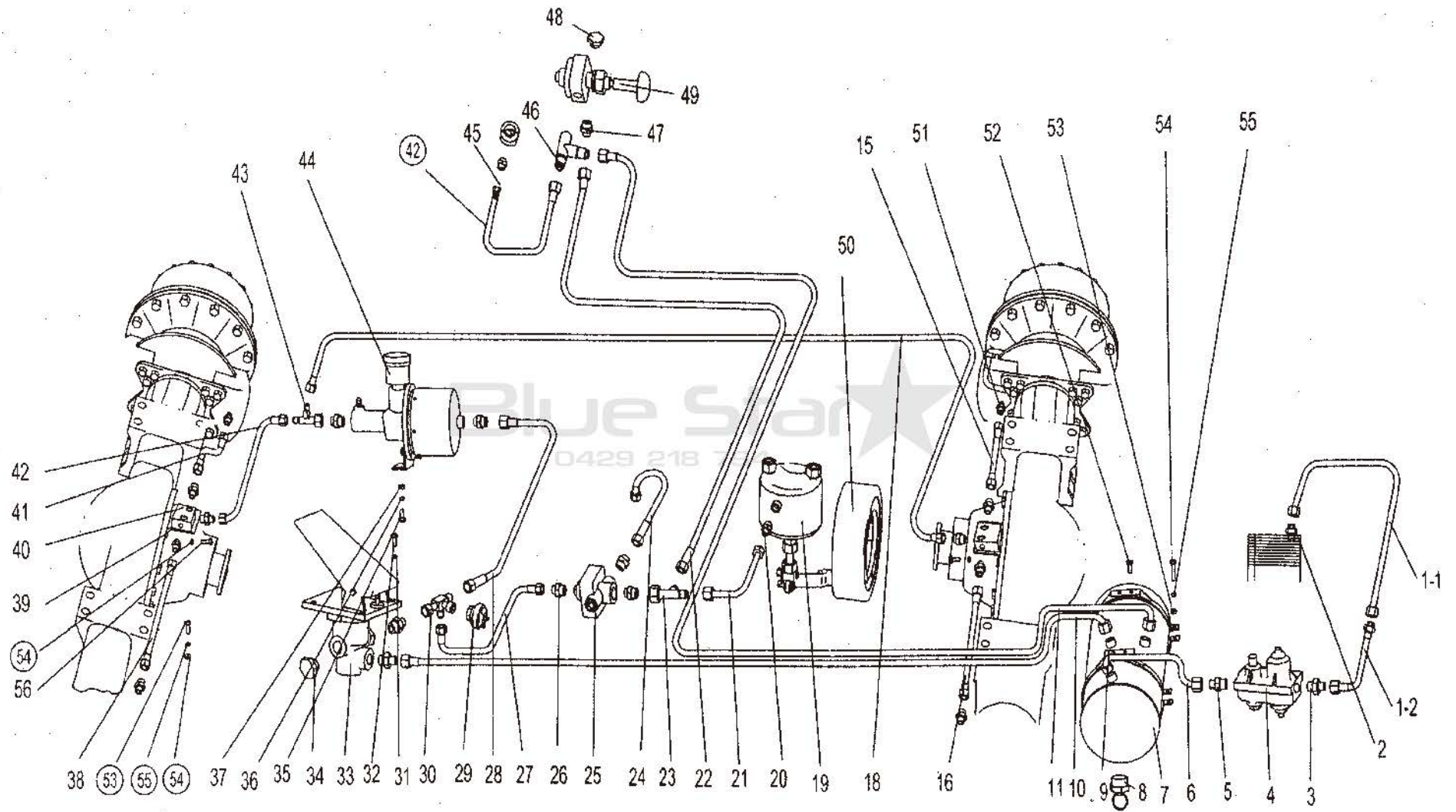

制动系统 Brake System

序号 Ser. No	零件名称 Part Name	数量 Qty	零件代号 Part No
1-1	空压机出气管 (XC6110)	1	
1- 2	连接软管 (830) (XC6110)	1	
1-1	空压机出气管 (R6105)	1	
1-2	连接软管 (600) (R6105)	1	
2	端式管接头	1	
3	油水分离器进气接头	1	
4	油水分离器组合阀	1	
5	油水分离器进出气接头	4	
6	贮气筒进气管	1	
7	贮气筒	1	
8	放水阀	1	
10	M18 制动软管 (2200)	1	
11	M14 制动软管 (3300)	1	
15	制动铜管 II	1	
16	制动支管 I	1	
18	后桥制动油软管	1	
19	驻车制动气室	1	
20	空心螺栓	1	
	组合密封垫圈 A12	2	
21	M14 制动软管 (540)	1	
22	手控制动阀出气管 (1500)	1	
23	气控截止阀三通接头	1	
24	M14 制动软管 (950)	1	

制动系统 Brake System

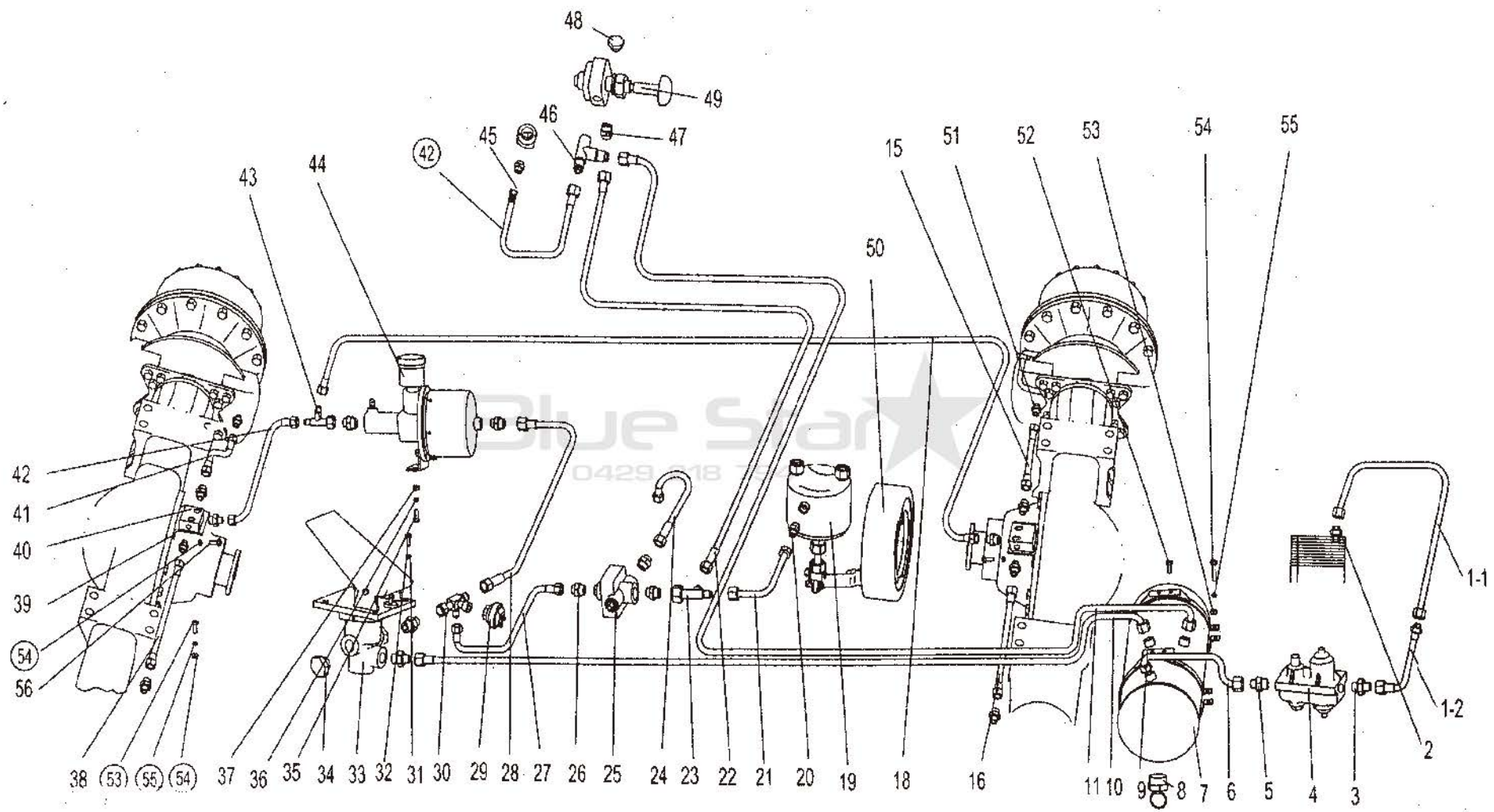

制动系统 Brake System

序号 Ser. No	零件名称 Part Name		数量 Qty	零件代号 Part No
25	气控截止阀	air-controlled cut-off valve	1	
26	气控截止阀接头	Connector of air-controlled cut-off valve	2	
27	M14 制动软管 (550)	Brake hose M14	1	
28	M18 制动软管 (1300)	Brake hose M18	1	
29	制动灯开头	Brake lamp switch	1	
30	刹车阀四通接头	4-way connector for air control brake valve	1	
31	垫圈 8	Washer 8	4	GB97-83
32	螺栓 M8X30	Bolt M8X30	4	GB5783-86
33	气制动阀(带脚踏板)	Air brake valve (with pedal)	1	
34	螺堵	Plug	1	
35	制动铜管 II	Brake pipe II	1	
36	螺栓 M12X30	Bolt M12X30	2	GB5780-86
37	垫圈 12	Washer 12	2	GB97-83
38	螺母 M12	Bolt M12	2	GB6170-86
39	三通板支架	Support of "T" board	2	
40	三通板	3-way board	2	
41	制动铜管 I	Brake pipe I	1	
42	M14 制动软管 (700)	Brake hose M14	2	
43	加力器三通接头	T connector of manual boosting pump	1	
44	空气加力泵	Air boosting pump	1	
45	气压表接头	Connector to barometer	1	
46	手控制动阀三通接头	"T" connector of manual brake valve	1	
47	出气接头	Air outlet connector	1	
48	手控制动阀堵头	Manual brake valve valve	1	

制动系统 Brake System

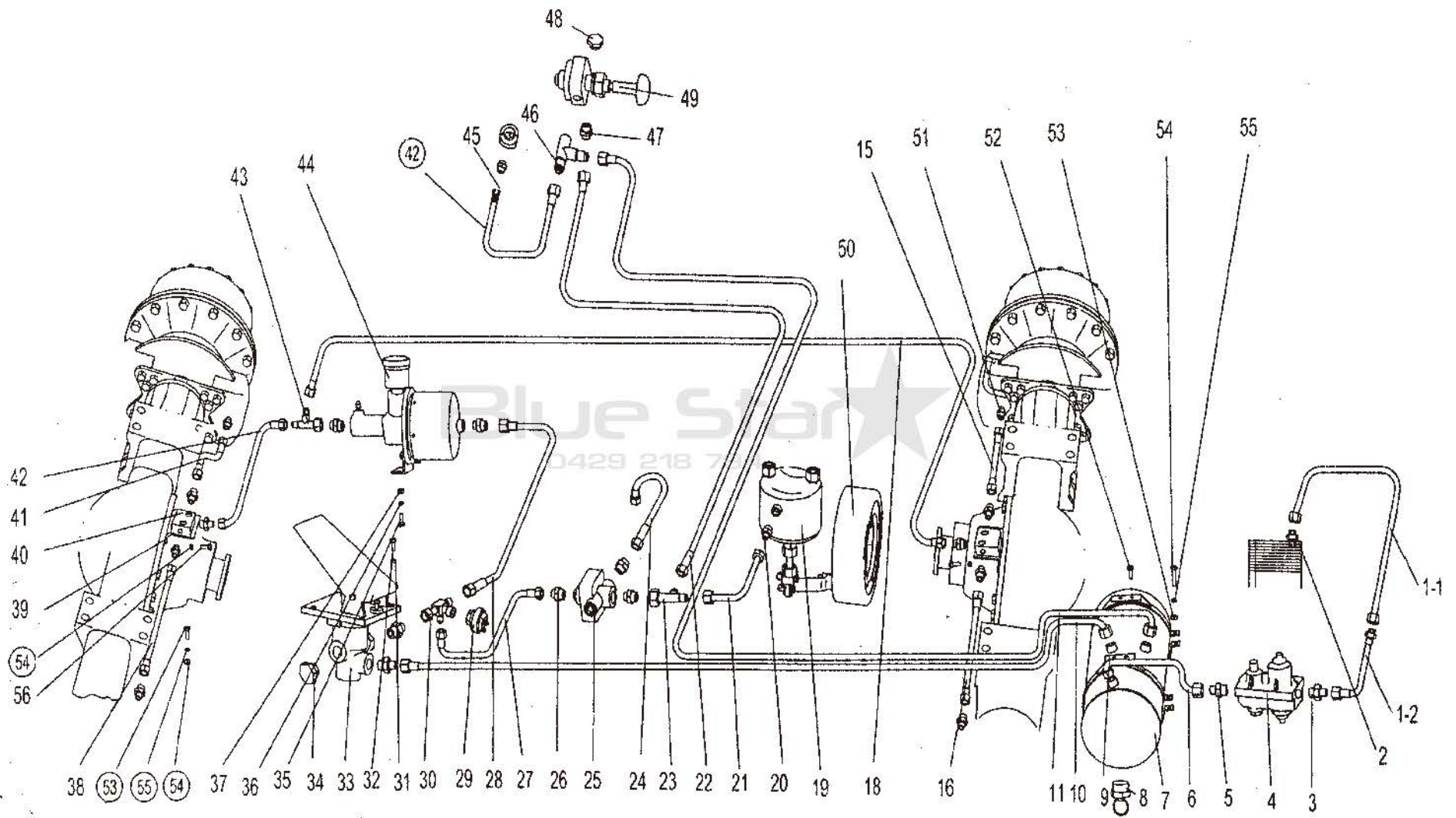

制动系统 Brake System

序号 Ser. No	零件名称 Part Name		数量 Qty	零件代号 Part No
49	手控制动阀	Manually controlled brake valve	1	
50	紧急与停车制动器总成	Emergency and parking brake assembly	1	
51	驻车制动气室接头	Air cavity connector for parking brake	11	
52	螺栓 M10X30	Bolt M10X30	6	GB5783-86
53	螺母 M10	Nut M10	10	GB6170-86
54	垫圈 10	Washer 10	10	GB93-87
55	螺栓 M10X80	Bolt M10X80	2	GB5780-86
56	螺栓 M10X20	Bolt M10X20	2	GB5783-86



空气加力泵 Booster

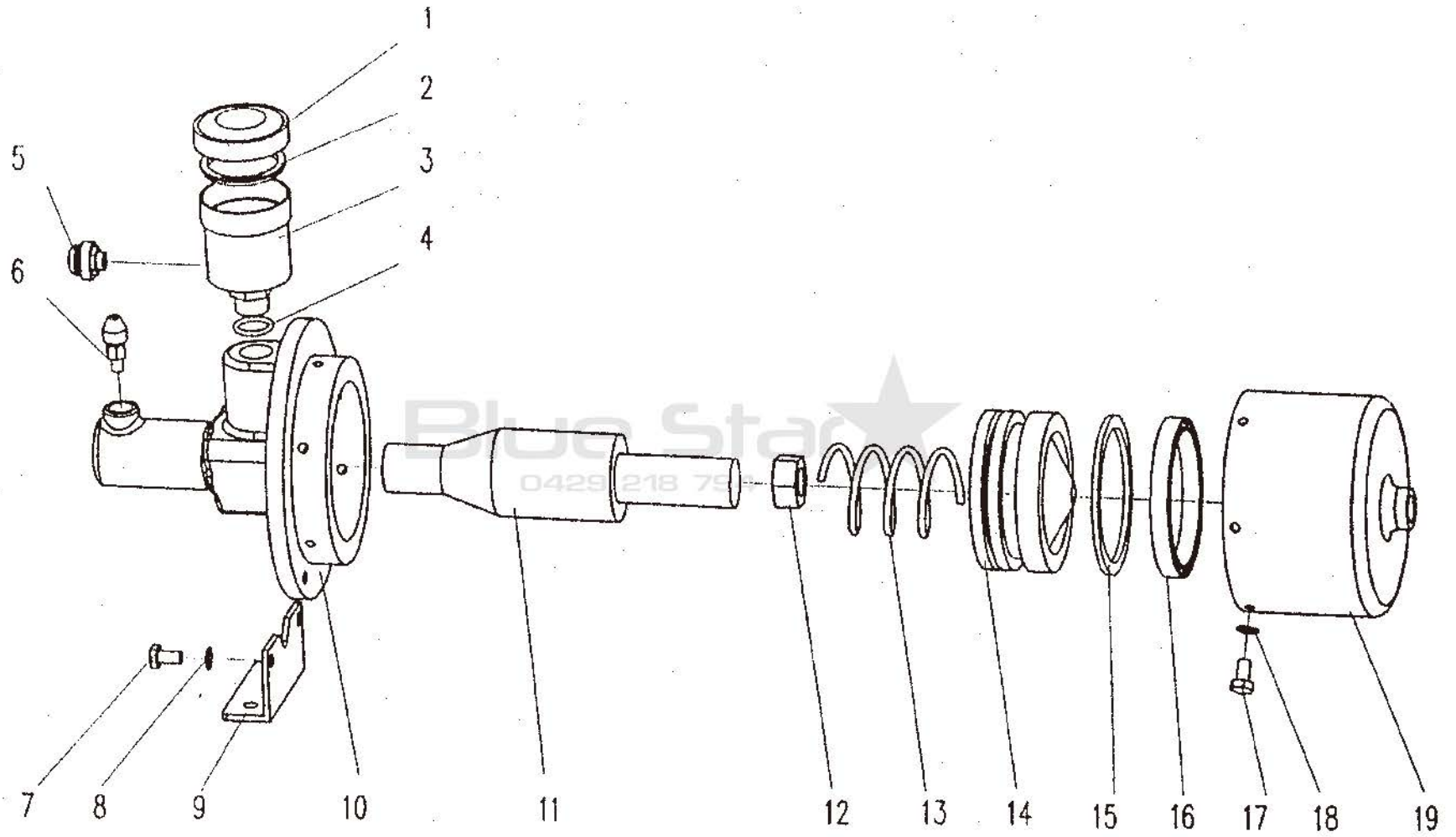

空气加力泵 Booster

序号 Ser. No	零件名称 Part Name		数量 Qty	零件代号 Part No
1	油杯盖	Oil cup cover	1	
2	过滤套	Filter sleeve	1	
3	油杯体	Oil cup	1	
4	O型圈 40X3.1	O ring 40×3.1	1	GB1235-76
5	放气嘴	Air valve	1	
6	接头	Connector	1	
7	螺栓 M10X35	Bolt M10x35	2	GB5781-86
8	垫圈 10	Washer 10	2	GB93-87
9	液压制动开关	Hydraulic brake switch	2	
10	支架	Bracket	1	
11	推杆	Push rod	1	
12	螺母 M12	Nut M12	1	GB6173-86
13	弹簧	Spring	1	
14	活塞	Piston	1	
15	密封圈	Seal Ring	1	
16	YX 密封圈	YX Seal Ring	2	GB5781-86
17	螺栓 M8X16	Bolt M8×16	6	GB859-86
18	垫圈 8	Washer 8	6	
19	制动泵体	Central brake pump	1	

紧急与停车制动器总成 Emergency and Parking Brake Assembly

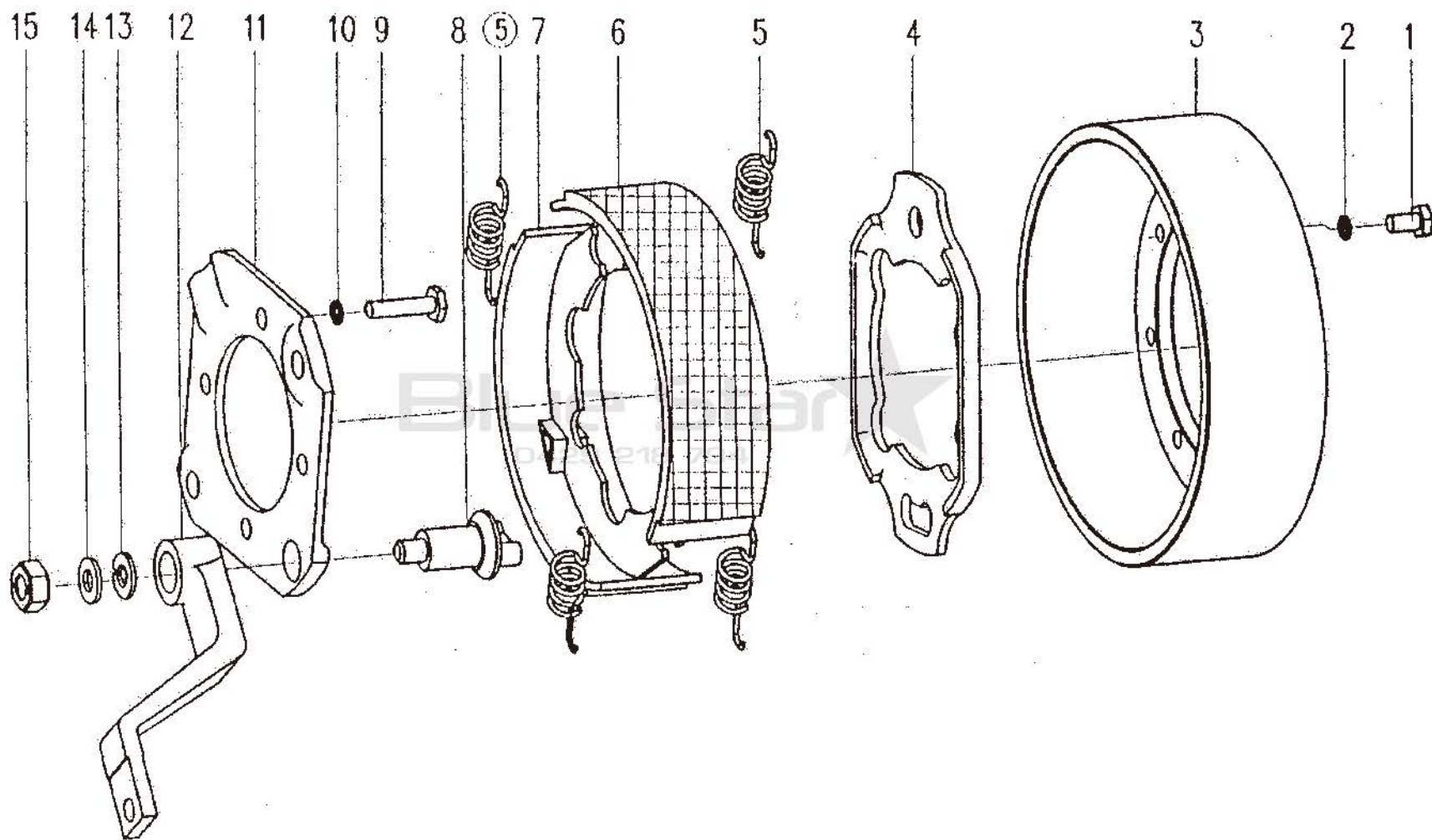

紧急与停车制动器总成 Emergency and Parking Brake Assembly

序号 Ser. No	零件名称 Part Name		数量 Qty	零件代号 Part No
1	螺栓 M10×25	Bolt M10×25	8	GB5781-86
2	垫圈 10	Washer 10	8	GB93-87
3	制动毂	Brake Hub	1	ZL30D-34-19-6
4	支承板总成	Support plate asm	1	ZL30D-34-19-2
5	制动蹄拉簧	Spring for brake hoof	4	ZL30D-34-19-5
6	制动蹄 I	Brake hoof I	1	ZL30D-34-19-1
7	制动蹄 II	Brake hoof II	1	ZL30D-34-19-4
8	拉杆轴	Linkage rod shaft	1	ZL30D-34-19-8
9	螺栓 12×25	Bolt M12×25	4	GB5783-86
10	垫圈 12	Washer 12	4	GB93-87
11	制动底板	Support [late	1	ZL30D-34-19-3
12	拉杆	Linkage rod	1	ZL30D-34-19-7
13	垫圈 14	Washer 14	1	GB93-87
14	垫圈 14	Washer 14	1	GB95-85
15	螺母 14	Nut M14	1	GB6170-86

传动液压系统 Transmission hydraulic system

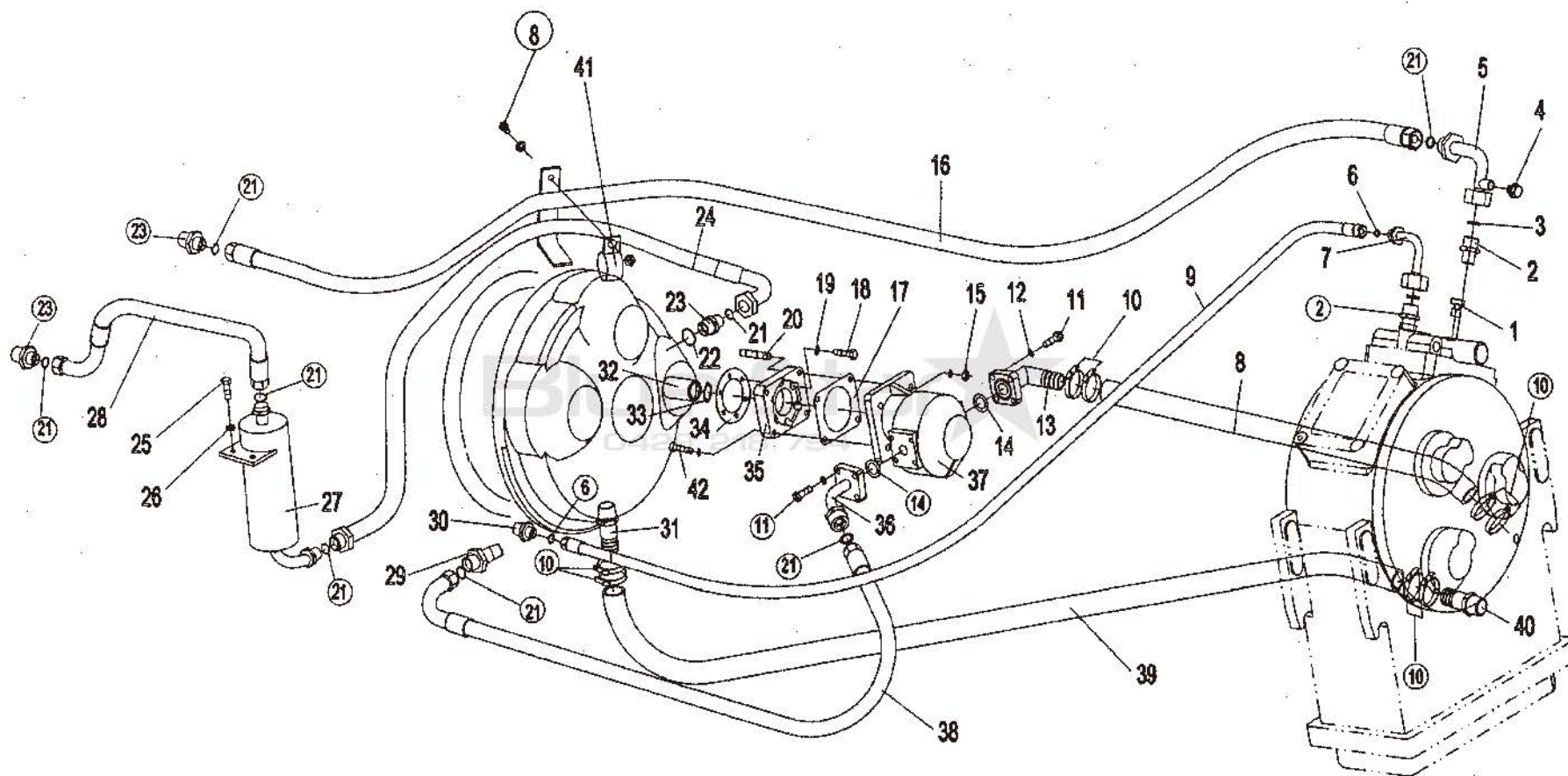

传动液压系统 Transmission hydraulic system

序号 Ser. NO	零件名称 Part name	数量 Qty	零件代号 Part No
1	堵头	1	
2	接头	2	
3	O形圈 20X1.8	5	GB3452.1-1982
4	螺塞 3/8"	1	Q/ZB285-1977
5	回油接头	1	
6	O形圈 13.2X1.8	2	GB3452.1-1982
7	操纵阀接头	2	
8	低压耐油胶管 L=580	1	
9	1/2" 高压胶管总成 L=850	1	
10	喉箍 d60	8	ZBJ15001-1987
11	螺栓 M10X30	8	GB5783-2000
12	垫圈 10	16	GB93-1987
13	传动泵进油口总成	1	
14	O形圈 37.5X3.55	2	GB3452.1-1982
15	螺母 M10	4	GB6170-1986
16	φ19 高压软管 (2400)	1	
17	垫片	1	ZL30D-28-12
18	螺钉 M8X20	6	GB70-1985
19	垫圈 8	6	GB93-1987
20	螺柱 M10X70	2	GB901-1988
21	O形圈 19X2.65	4	GB3452.1-1982
22	O形圈 25X3.55	3	GB3452.1-1982
23	接头	2	
24	φ19 高压软管 (2100)	1	

传动液压系统 Transmission hydraulic system

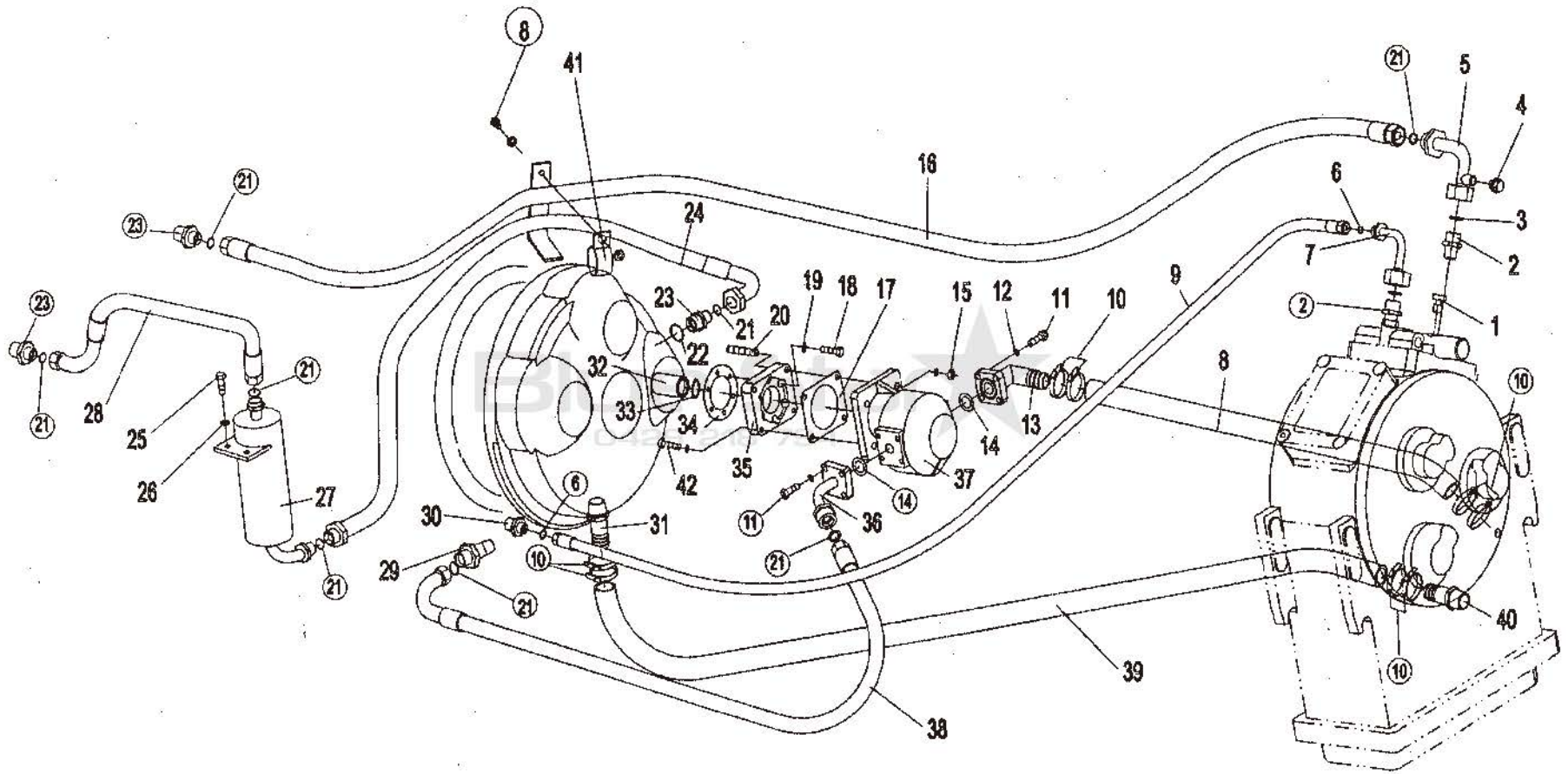

传动液压系统 Transmission hydraulic system

序号 Ser. NO	零件名称 Part name		数量 Qty	零件代号 Part No
25	螺栓 M12X25	BOLT M12X25	2	GB5783-2000
26	垫圈 12	LOCK WASHER 12	2	GB93-1987
27	回油滤油器总成	OIL FILTER	1	
28	φ 19 高压软管 (900)	φ 19 HIGH PRESSURE OIL RESISTANT HOSE	1	
29	减压阀进油口接头	PRESSURE VALVE OIL INLET CONNECTOR ASSEMBLY	1	
30	减压阀出油口接头	PRESSURE VALVE OIL OUTLET CONNECTOR ASSEMBLY	1	
31	软管接头	ADAPTER	1	
32	油泵连接套	JOINT SLEEVE OF OIL PUMP	1	ZL30D-28-13
33	挡圈 25	SNAP RING 25	1	GB894.1-1986
34	垫片	SPACER	1	ZL30D-26-8
35	联接盘	COUPLING DISC	1	ZL30D-28-14
36	CB32 泵出油口总成	PUMP OIL OUTLET CONNECTOR	1	
37	齿轮油泵	OIL PUMP	1	CB32
38	φ 19 高压胶管总成 L=780	φ 19 HIGH PRESSURE OIL RESISTANT HOSE	1	
39	低压耐油胶管 L=950	LOW PRESSURE OIL RESISTANT HOS	1	
40	接头	ADAPTER	1	
41	管卡	CLAMP	1	
42	螺栓 M10X20	BOLT M10X20	2	GB5783-2000

回油滤清器总成 Return Oil Filter Assembly

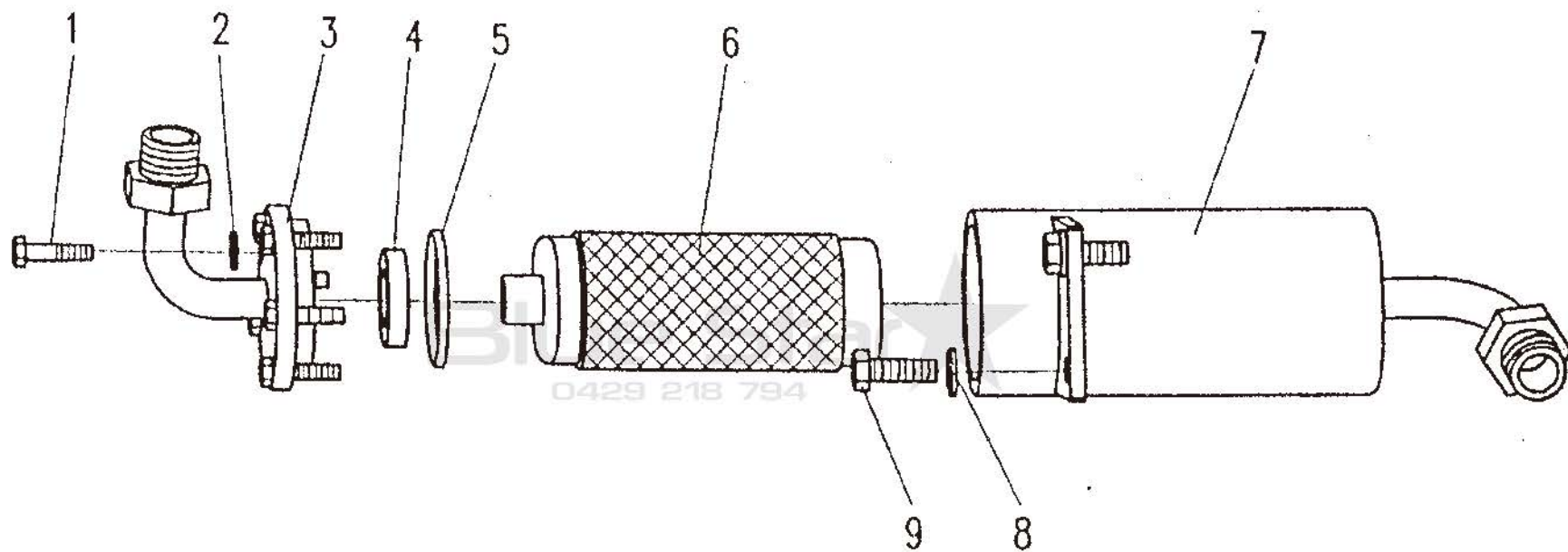

回油滤清器 Return Oil Filter

序号 Ser. No	零件名称 Part Name		数量 Qty	零件代号 Part No
1	螺栓 M8×35	Bolt M8×35	6	GB5783-2000
2	垫圈 8	Lock washer 8	6	GB93-1987
3	上盖	Top Cover	1	
4	O型圈 77×2.5	"O" ring 77×2.5	1	
5	平胶垫	Rubber Space	1	
6	滤网总成	Filter Screen Assembly	1	
7	壳体	Housing	1	
8	垫圈 12	Lock washer 12	2	GB93-1987
9	螺栓 M12×20	Bolt M12×20	2	GB5783-2000

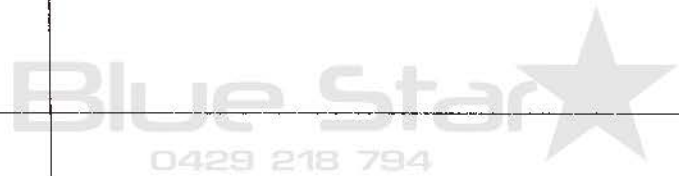

转向液压系统 Steering Hydraulic System

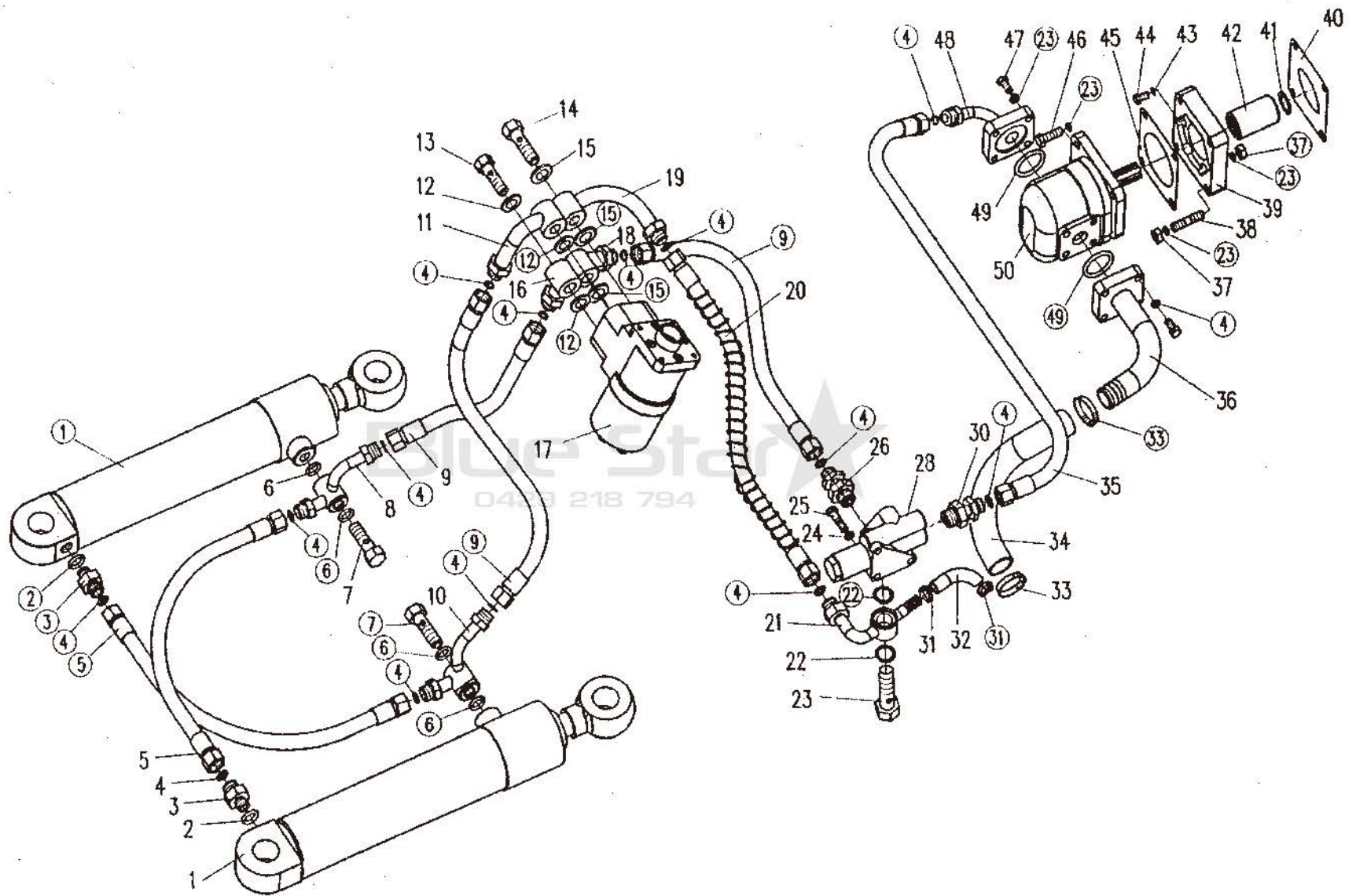

转向液压系统 Steering Hydraulic System

序号 Ser. No	零件名称 Part Name	数量 Qty	零件代号 Part No
1	转向油缸 80×294	2	
2	O型圈 21.2x2.65	2	GB3452.1-1982
3	转向油缸接头	2	
4	O型圈 13.2x1.8	14	GB3452.1-1982
5	1/2" 高压胶管总成 (582)	2	
6	O型圈 19x2.65	6	GB3452.1-1982
7	空心螺栓	2	
8	右转向缸接头总成	1	
9	1/2" 高压胶管总成 (650)	3	
10	左转向缸接头总成	1	
11	转向器右转向油口弯头总成	1	
12	组合密封垫圈 18	4	JB982-1977
13	空心螺栓	2	
14	转向器空心螺栓	2	
15	组合密封垫圈 20	4	JB982-1977
16	转向器左转向油口弯头总成	1	
17	全液压转向器 BZZ1-400	1	BZZ1-400
18	转向器进油口接头总成	1	
19	转向器回油口弯头总成	1	
20	1/2" 高压胶管总成 (582)	1	
21	三通接头	1	
22	O型圈 23.6x3.55	2	
23	空心螺栓	1	
24	垫圈 10	17	GB93-1987

转向液压系统 Steering Hydraulic System

序号 Ser. No	零件名称 Part Name	数量 Qty	零件代号 Part No
1	转向油缸 80×294	2	
2	O型圈 21.2x2.65	2	GB3452.1-1982
3	转向油缸接头	2	
4	O型圈 13.2x1.8	14	GB3452.1-1982
5	1/2" 高压胶管总成 (582)	2	
6	O型圈 19x2.65	6	GB3452.1-1982
7	空心螺栓	2	
8	右转向缸接头总成	1	
9	1/2" 高压胶管总成 (650)	3	
10	左转向缸接头总成	1	
11	转向器右转向油口弯头总成	1	
12	组合密封垫圈 18	4	JB982-1977
13	空心螺栓	2	
14	转向器空心螺栓	2	
15	组合密封垫圈 20	4	JB982-1977
16	转向器左转向油口弯头总成	1	
17	全液压转向器 BZZ1-400	1	BZZ1-400
18	转向器进油口接头总成	1	
19	转向器回油口弯头总成	1	
20	1/2" 高压胶管总成 (582)	1	
21	三通接头	1	
22	O型圈 23.6x3.55	2	
23	空心螺栓	1	
24	垫圈 10	17	GB93-1987

转向液压系统 Steering Hydraulic System

序号 Ser. No	零件名称 Part Name		数量 Qty	零件代号 Part No
25	螺栓 M10x55	Bolt M10x55	3	GB5780-1986
26	单稳阀接口 II	Pipe II to single stable valve	1	
28	单路稳定分流阀 FLD-30-Z	Single stable divider valve	1	FLD-30-Z
30	单稳阀接口 I	Pipe I to single stable valve	1	
31	O 型圈 19x2.65	O-ring 19x2.65	2	GB3452.1-1982
32	φ19 高压软管 (1000)	φ19 HIGH PRESSURE OIL RESISTANT HOSE	1	
33	喉箍 d60	Clamp d60	4	ZBJ15001-1987
34	低压耐油胶管	Low pressure oil resistant tube	1	
35	1/2" 高压胶管总成 (785)	1/2" high pressure tube say	1	
36	转向油泵进油口弯头总成	Inlet elbow of steering pump	1	
37	螺母 M10-6	Nut M10-6	4	GB901-1988
38	螺柱 M10x70	Bolt M10x70	2	
39	联接盘	Coupling disc	1	
40	垫片	Spacer	1	GB894.1-1986
41	挡圈 25	Snap Ring 25	1	
42	油泵连接套	Joint sleeve of pump	1	
43	垫圈 8	Washer 8	6	GB93-87
44	螺钉 M8x20	Screw M8x20	6	
45	垫片	Spacer	1	GB70-85
46	螺栓 M10x35	Bolt M10x35	2	
47	螺栓 M10x30	Bolt M10x30	8	GB5783-2000
48	转向油泵出油口弯头总成	Outlet elbow of steering pump	1	
49	O 型圈 37.5x3.55	O-ring 37.5x3.55	2	GB3452.1-1982
50	转向油泵 CBN-E550	Steering pump	1	

转向油缸 Steering Cylinder

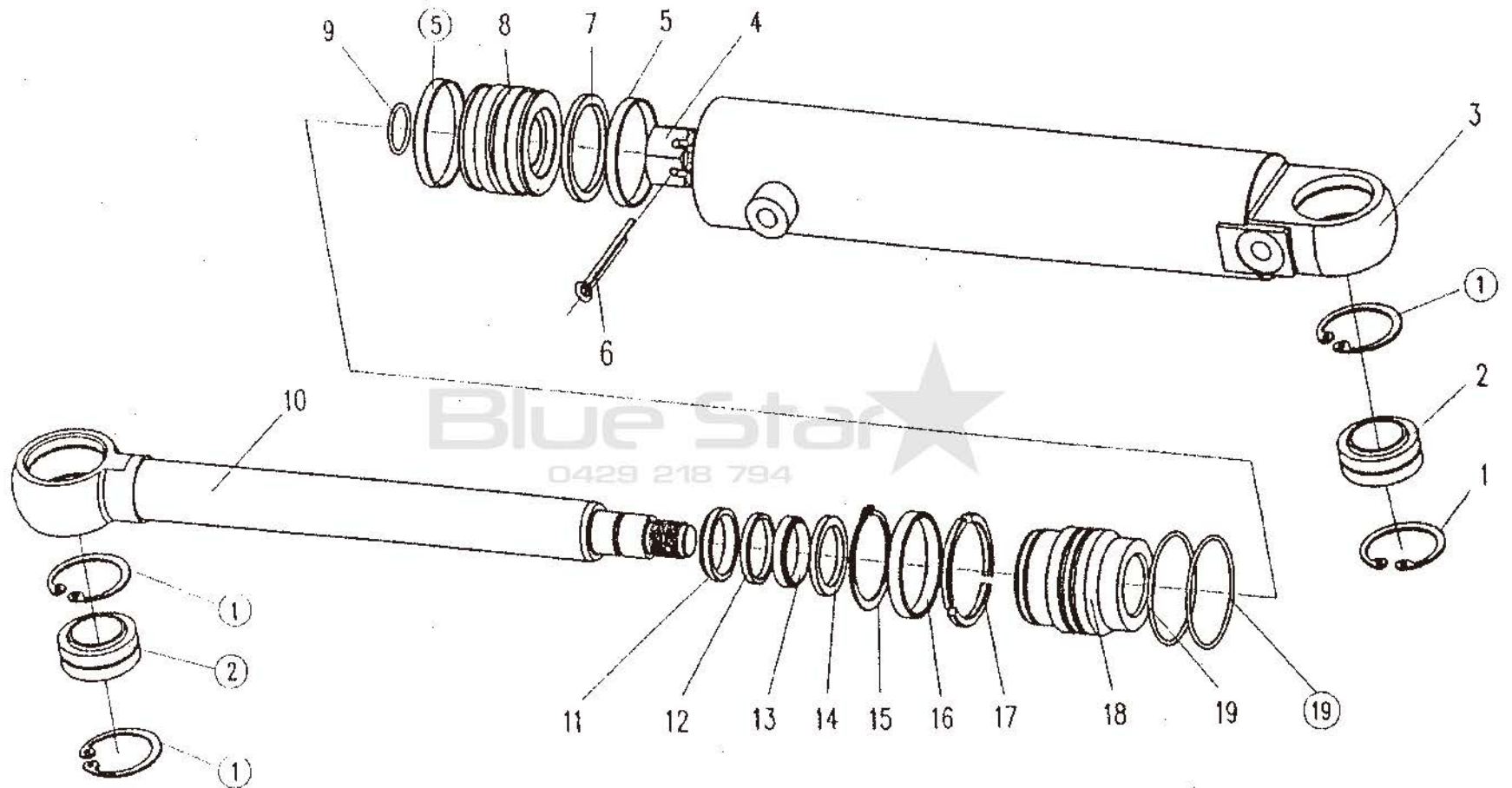

转向油缸 Steering Cylinder

序号 Ser. NO	零件名称 Part name		数量 Qty	零件代号 Part No
1	挡圈 62	Snap ring 62	4	GB893.1-1986
2	关节轴承 GE40ES	Joint bearing GE40ES	2	GB304.5-1981
3	缸体	Cylinder block	1	ZL30F.30.1
4	槽形螺母 M30X2	Slot nut M30×2	1	GB6178-1986
5	支承环	Support ring D80xd75x9.5	2	
6	开口销 5X50	Split pin 5x50	1	GB91-1986
7	组合滑环 ZHQD80	Combined slide ring ZHQD80	1	
8	活塞	Piston	1	ZL30F.30-2
9	O形圈 32X3.1	"O" ring 32x3.1	1	GB1235-1976
10	活塞杆	Piston rod	1	ZL30F.30-6
11	防尘圈 d45XD55X10	Dust ring d45xD55x10	1	
12	挡圈 d45XD53X2	Snap ring d45xD53x2	1	
13	派克密封圈	seal ring of parker	1	BS 4555 P5008
14	组合滑环 ZHQd45	Combined slide ring ZHQd45	1	
15	挡圈 72	Snap ring 72	1	GB894.1-1986
16	挡环	Snap ring	1	ZL30F.30-5
17	卡键	Clip for hole	1	ZL30F.30-4
18	导向套	Guide sleeve	1	ZL30F.30-3
19	O形圈 80X3.1	"O" ring 80x3.1	2	GB1235-1976

转向器总成 Steering Unit Assembly

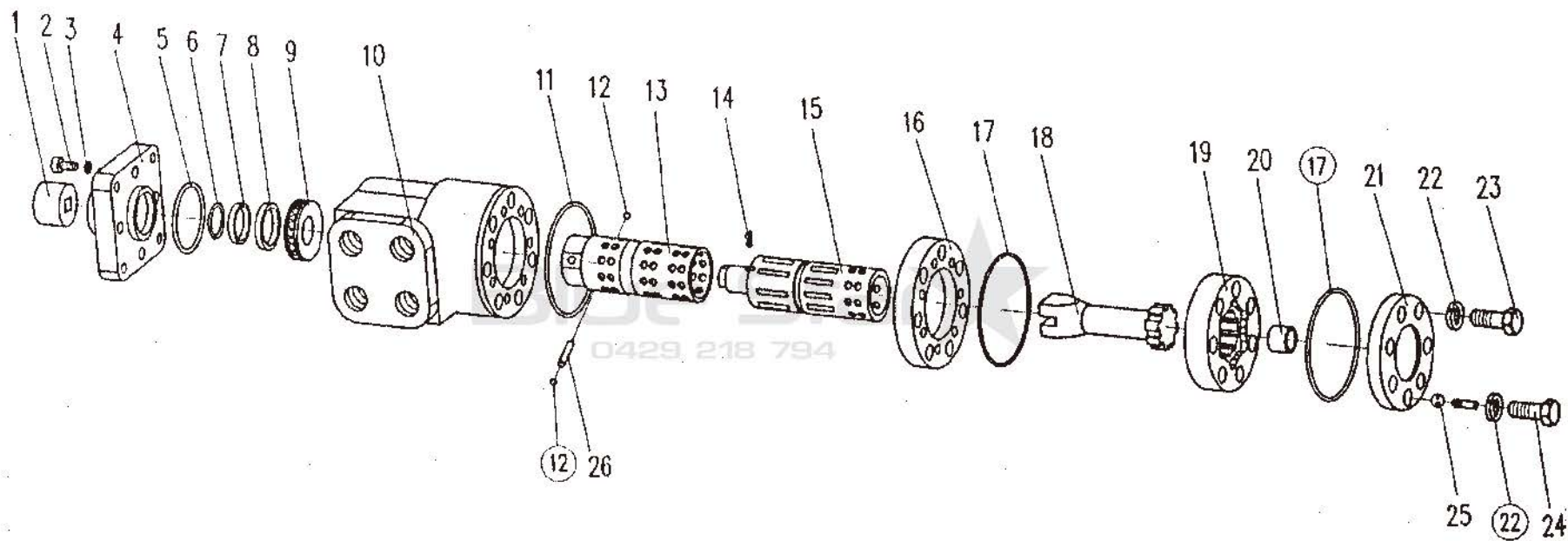

转向器总成 Steering Unit Assembly

序号 Ser. No	零件名称 Part Name		数量 Qty	零件代号 Part No
1	连接块组件	Connecting block	1	BZZ-1-00
2	螺钉 M8x20	Screw M8x20	4	GB70-1985
3	垫圈 8	Washer	4	GB859-1987
4	前盖	Front cover	1	BZZ-00-01
5	O 型圈 50x3.1	O-ring 50×3.1	1	GB1235-1976
6	O 型圈 24x2.4	O-ring 24×2.4	1	GB1235-1976
7	X 型密封圈	"X" seal ring	1	BZZ-00-166
8	垫	Gasket	1	
9	推力滚针轴承 7589104	Thrust needle bearing 7589104	1	
10	阀体	Valve block	1	BZZ-00-10(a)
11	O 型圈 95x3.1	O-ring 95x3.1	2	GB1235-1976
12	垫片	Gasket	1	BZZ-00-06
13	阀套	Valve sleeve	1	BZZ3-00-09
14	弹簧片	Spring	1	BZZ-00-04
15	阀芯	Valve spool	1	BZZ3-00-08
16	隔盘	Lsoating plate	1	BZZ-00-11(a)
17	O 型圈 96x1.9	O-ring 96×1.9	2	BZZ-00-17
18	连动轴	Coupling shaft	1	BZZ-00-07
19	定子组件	Stator module	1	BZZ-03-00(a)
20	限位块	Stopper	1	BZZ-00-14
21	后盖	Rear cover	1	BZZ-00-18(a)
22	铜垫 10	Coopper spacer 10	7	BZZ-00-19
23	六角螺栓 M10x1xL	Hex bolt M10x1xL	6	BZZ-00-18
24	限位螺柱组件	Caging bolt module	1	BZZ-02-00

转向器总成 Steering Unit Assembly

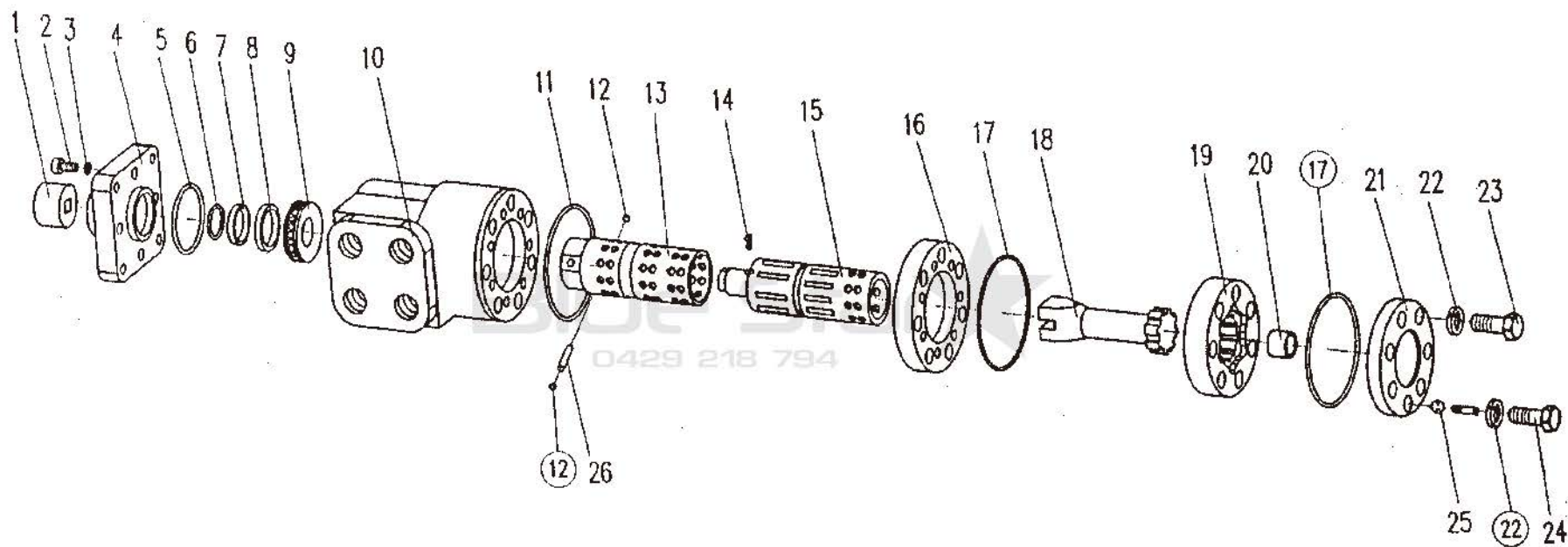

转向器总成 Steering Unit Assembly

序号 Ser. No	零件名称 Part Name		数量 Qty	零件代号 Part No
25	钢球 $\phi 7$	Steel ball $\phi 7$	1	GB308-1989
26	拨销	Center pin	1	BZZ-00-05
			1	
			1	
			1	



单路稳定分流阀总成 Single Stable Dividing Valve Assembly

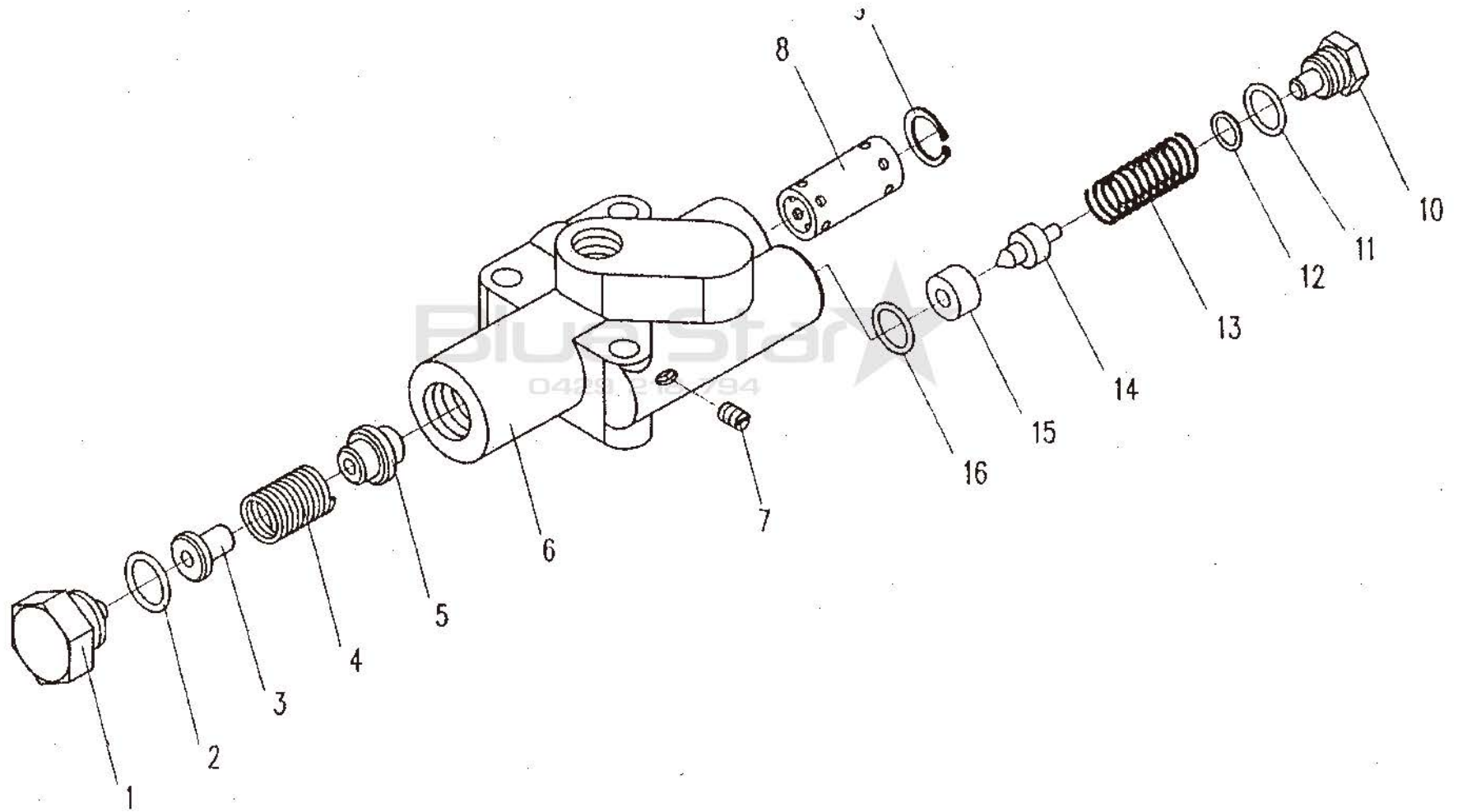

单路稳定分流阀总成 Single Stable Dividing Valve Assembly

序号 Ser. No	零件名称 Part Name		数量 Qty	零件代号 Part No
1	堵塞	Plug	1	
2	O型圈	O-ring	1	
3	导套定位螺堵	Set plug for guide sleeve	1	
4	弹簧	Spring	1	
5	阻尼塞	Damping plug	1	
6	阀体	Valve body	1	
7	油堵	Oil plug	1	
8	阀芯	Valve spool	1	
9	挡圈	Snap ring	1	
10	安全阀堵塞	Plug for safety valve	1	
11	O型圈	O-ring	1	
12	安全阀垫片	Spacer for safety valve	1	
13	弹簧	Spring	1	
14	安全阀阀芯	Safety valve spool	1	
15	安全阀阀座	Safety valve seat	1	
16	O型圈 28x3.5	O-ring 28x3.5	1	

工作装置液压系统 Working hydraulic system

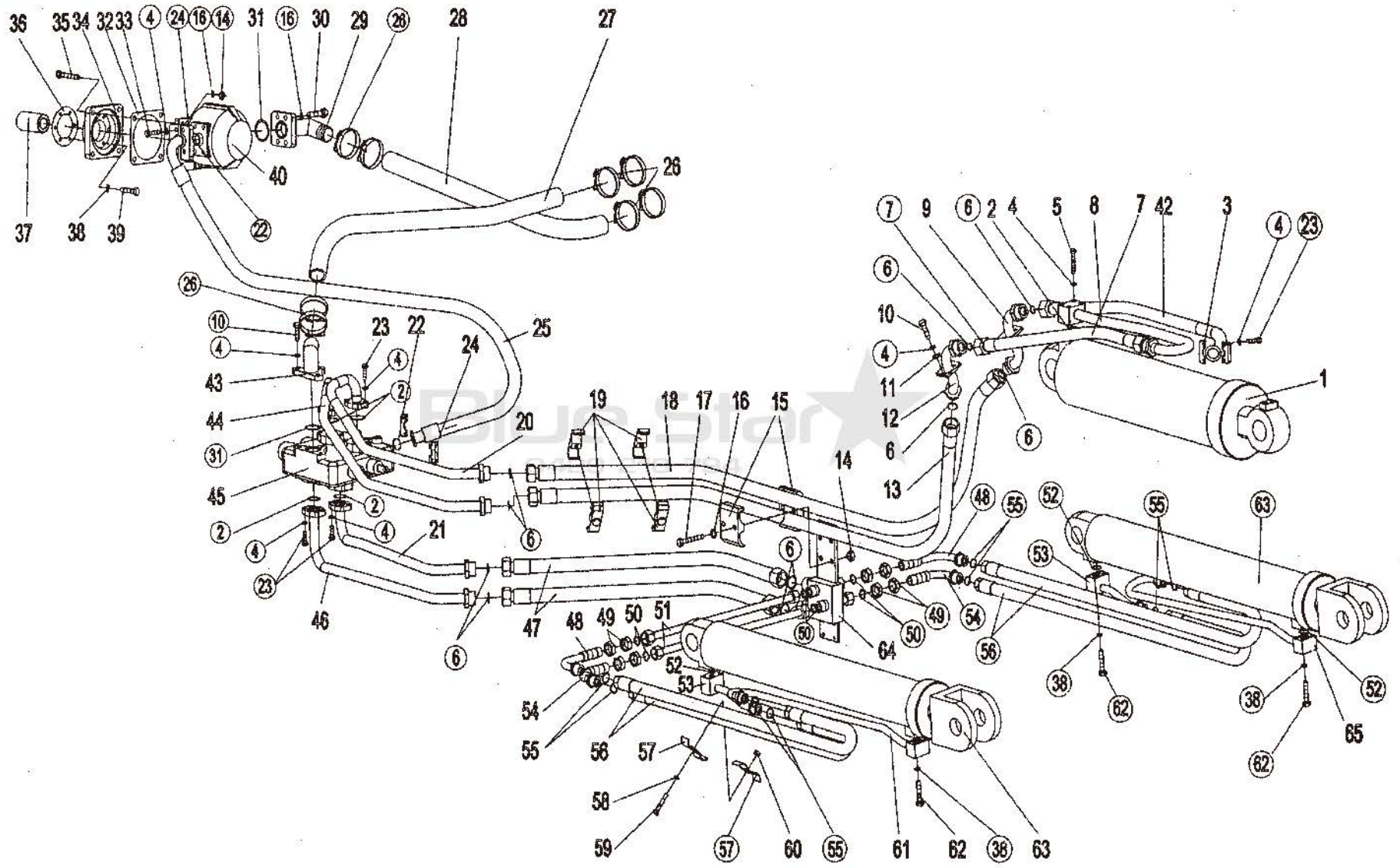

工作装置液压系统 Working hydraulic system

序号 Ser. NO	零件名称 Part name	数量 Qty	零件代号 Part No
1	转斗缸 160X499	1	
2	O 形圈 28X3.55	1	GB3452.1-1982
3	拼合法兰	1	
4	垫圈 10	37	GB93-1987
5	螺栓 M10X65	4	GB5782-2000
6	O 形圈 23.6X2.65	11	GB3452.1-1982
7	φ25 高压软管总成 (910)	1	
8	收斗弯管总成 (法兰式)	1	
9	转斗缸左接头	1	
10	螺栓 M10X25	5	GB5783-2000
11	垫圈 10	4	GB95-1985
12	转斗缸油管右接头	2	
13	φ25 高压软管总成 (1550)	1	
14	螺母 M12	6	GB6170-86
15	双管卡	2	
16	垫圈 12	10	GB93-87
17	螺栓 M12X95	2	GB5782-86
18	φ25 高压软管总成 (1400)	1	
19	双管卡	2	
20	硬管总成	1	
21	硬管总成	1	
22	O 形圈 32.5X3.55	2	GB3452.1-1982
23	螺栓 M10X30	24	GB5783-2000
24	拼合法兰	2	

工作装置液压系统 Working hydraulic system

序号 Ser. NO	零件名称 Part name	数量 Qty	零件代号 Part No
25	φ25 高压软管总成	1	ZBJ15001-1987
26	喉箍 d70	8	
27	工作阀回油低压胶管	1	
28	工作泵吸油管	1	ZL30D-26-14 GB5781-2000
29	CBG2100 油泵进油口	1	
30	螺栓 M12X35	8	
31	O 形圈 42.5X3.55	2	GB3452.1-82
32	垫片	1	ZL30D-26-22
33	螺栓 M10X35	4	GB5781-86
34	CBG2100 油泵连接盘	1	ZL30D-26-9
35	螺栓 M12X55	4	GB5780-86
36	垫片	1	ZL30D-26-8
37	CBG2100 油泵连接套	1	ZL30D-26-7
38	垫圈 8	22	GB93-87
39	螺钉 M8X25	6	GB70-85
40	齿轮油泵 CBG2100	1	CBGj2100
41			
42			
43	工作分配阀回油口	1	DF25.2C DF25.3C
44	硬管总成	1	
45	工作分配阀 DF25.2C	1	
	工作分配阀 DF25.3C(叉子用)	1	
46	硬管总成	1	
47	φ25 高压软管总成 (850)	2	
48	动臂缸下降接头	2	

工作装置液压系统 Working hydraulic system

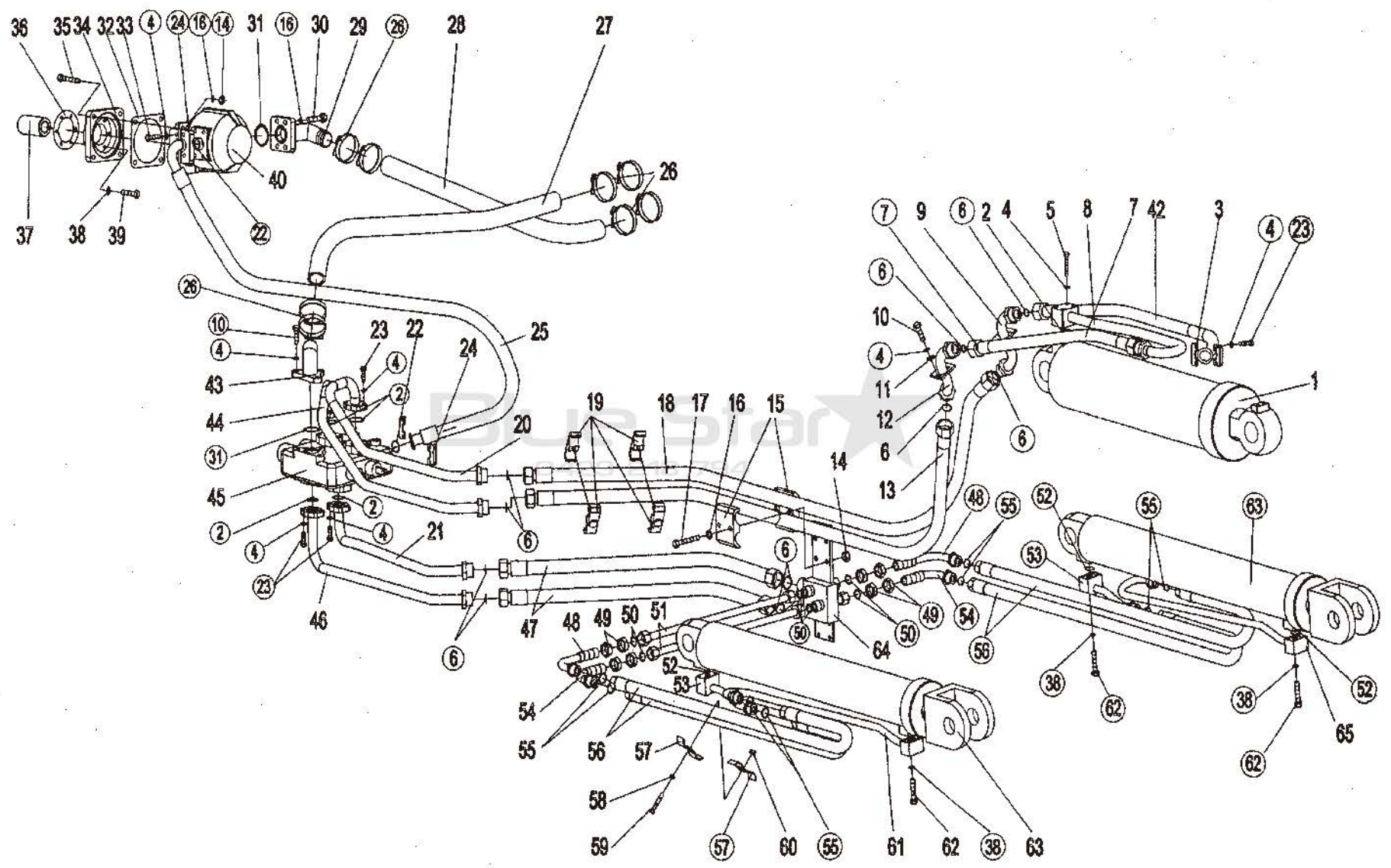

工作装置液压系统 Working hydraulic system

序号 Ser. NO	零件名称 Part name		数量 Qty	零件代号 Part No
49	接口螺母	Nut on adapter	8	GB3452.1-1982
50	O形圈 15X1.8	"O" ring 15X1.8	4	
51	中管	Mid-pipe	2	
52	O形圈 23.6X3.55	"O" ring 23.6X3.55	4	GB3452.1-1982
53	举升接头(法兰式)	Lifting adapter(flange type)	2	
54	动臂缸举升接头	Lifting adapter of lift cylinder	2	
55	O形圈 20X1.8	"O" ring 20X1.8	10	GB3452.1-1982
56	动臂油缸油管	Oil tube of lift cylinder	4	
57	动臂油管卡	Tube clip	4	
58	垫圈 6	Washer 6	2	GB93-1987
59	螺栓 M6X35	Bolt M6X35	4	GB5780-2000
60	螺母 M6	Nut M6	2	GB6170-2000
61	下降右接头(法兰式)	Lowering right adapter(flange type)	1	GB5782-2000 110X780
62	螺栓 M8X55	Bolt M8X55	16	
63	举升缸	Lift cylinder	2	
64	板座总成	Oil board	1	
65	下降左接头(法兰式)	Lowering left adapter(flange type)	1	

工作分配阀 Working distribution valve

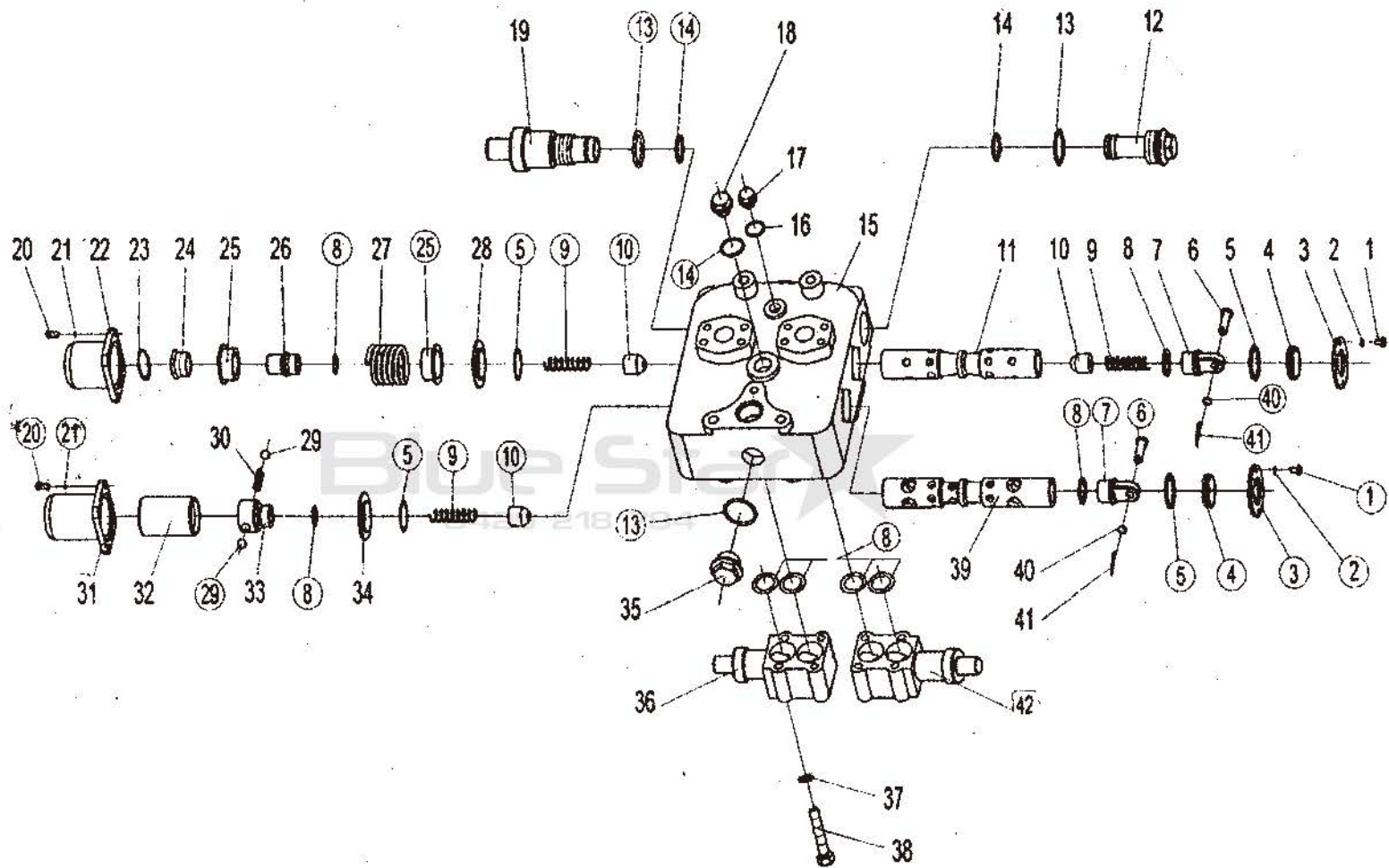

工作分配阀 Working distribution valve

序号 Ser. NO	零件名称 Part name	数量 Qty	零件代号 Part No
1	螺钉 M6X10	8	GB818-1985
2	垫圈 6	8	GB93-1987
3	挡板	2	DF25-10
4	防尘圈	2	DF25-11
5	“O”形圈 41X3.5	4	GB1235-1976
6	销轴	2	DF32-13
7	销轴座	2	DF25-12
8	“O”形圈 28X3.1	4	GB1235-1976
9	弹簧	3	DF25-03
10	单向阀	3	DF25-02
11	阀杆 O	1	DF25-06
12	堵头	1	DF32-08
13	“O”形圈 40X3.1	3	GB1235-1976
14	“O”形圈 30X3.1	2	GB1235-1976
15	阀体	1	DF25.2-01C (C1)
16	“O”形圈 22X2.4	1	GB1235-1976
17	螺塞	1	DF32-09
18	螺塞	1	DF32-14
19	安全阀组合件	1	DF32-07
20	螺栓 M8X20	8	GB5780-1986
21	垫圈 8	8	GB93-1987
22	端盖	1	
23	挡圈 20	1	GB894.1-1986
24	压盖	1	

工作装置总成 Working Equipment Assembly

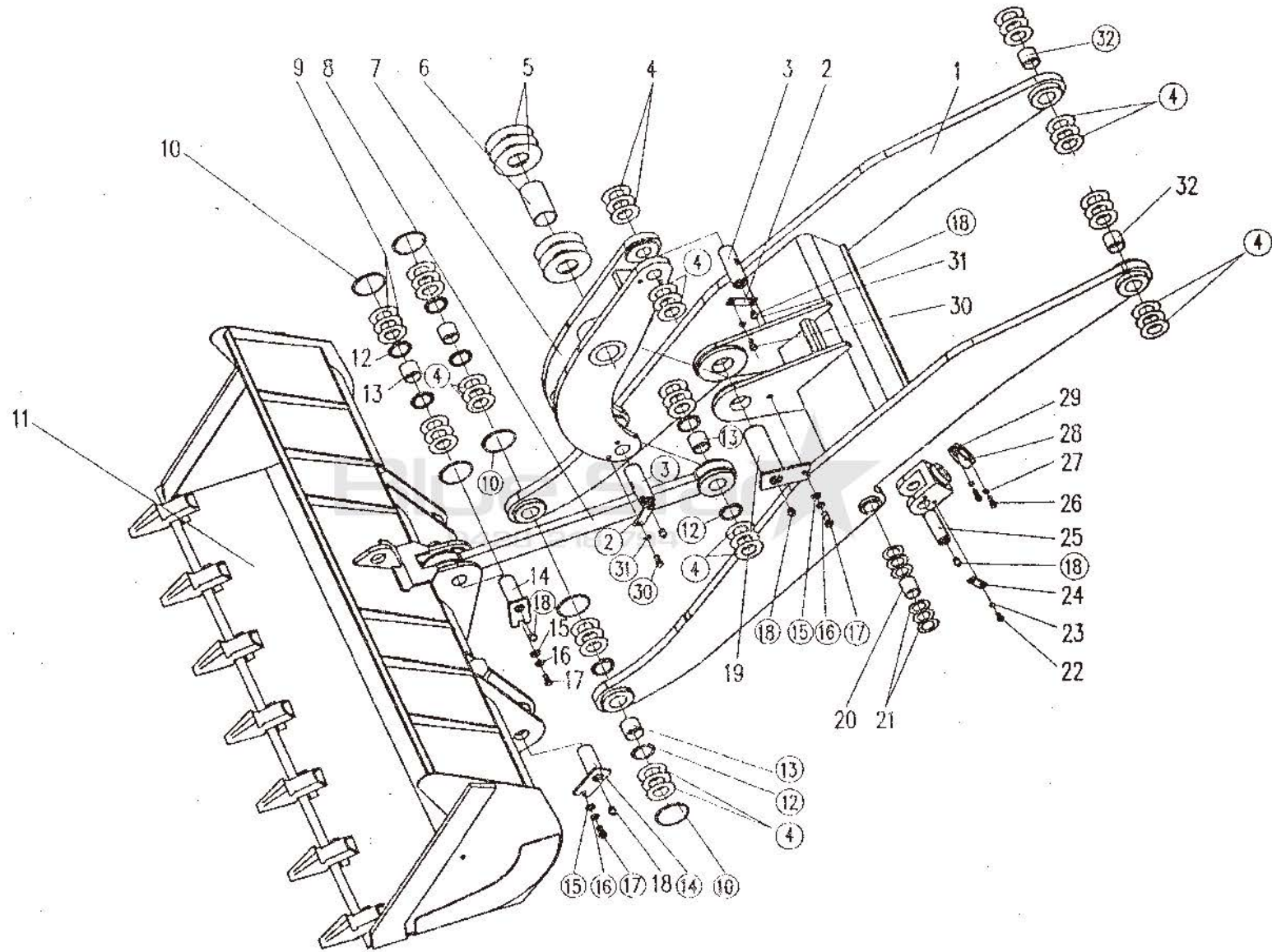

工作分配阀 Working distribution valve

序号 Ser. NO	零件名称 Part name		数量 Qty	零件代号 Part No
25	弹簧座	RETAINER	2	
26	限位柱	SET COLUMN	1	
27	弹簧	SPRING	1	
28	压板	CLAMPING PLATE	1	
29	钢球 $\Phi 11$	STEEL BALL $\Phi 11$	2	GB308-1989
30	定位弹簧	SET SPRING	1	
31	端盖	END COVER	1	
32	定位套	SET SLEEVE	1	
33	定位柱	SET COLUMN	1	
34	压板	CLAMPING PLATE	1	
35	螺塞	THREAD PLUG	1	DF32-15
36	过载阀组合件(大腔)	OVERLOAD VALVE	1	QZF1-00
37	垫圈 10	WASHER 10	8	GB93-1987
38	螺栓 M10X68	BOLT M10X68	8	GB5782-1986
39	阀杆 Q	VALVE SPOOL	1	DF25-01
40	垫圈 12	WASHER 12	2	GB97.1-1985
41	开口销 4X20	SPLIT PIN4X20	2	GB91-1986
42	过载阀组合件(小腔)	OVERLOAD VALVE	1	QZF1-00

齿轮泵 Gear Pump

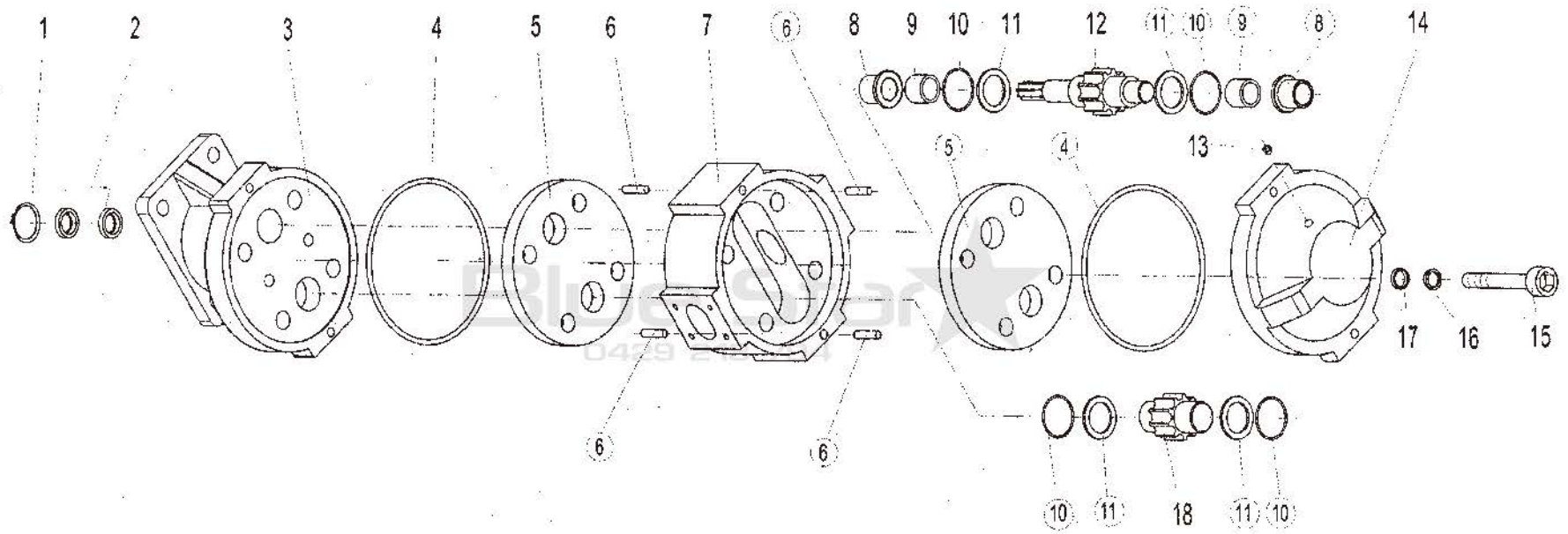

齿轮泵 Gear Pump

序号 Ser. NO	零件名称 Part name		数量 Qty	零件代号 Part No
1	挡圈 52	Snap ring 52	1	GB893.1-1986
2	骨架式油封 PG32X52X12	Skeleton type oil PG32X52X12	2	HG4-692-1967
3	前泵盖	Front cover	1	
4	O形圈 140X3.1	"O" ring 140X3.1	2	GB1235-1976
5	侧板	Side plate	2	
6	圆柱销 8X20	Pin 8X20	4	GB119-1986
7	泵体	Pump body	1	
8	密封环	Seal ring	2	
9	滚针轴承 35X51X32	Needle roller 35X51X32	2	644907
10	密封圈	Seal ring	4	
11	挡圈	Snap ring	4	
12	主动齿轮	Drive gear	1	
13	螺塞 ZG1/8"	Thread plug	1	
14	后泵盖	Rear cover	1	
15	螺钉 M16X132	Screw M16X132	4	
16	垫圈 16	Washer 16	4	GB93-1987
17	法兰	flange	4	
18	从动齿轮	Driven gear	1	

转斗油缸 Tilt Cylinder

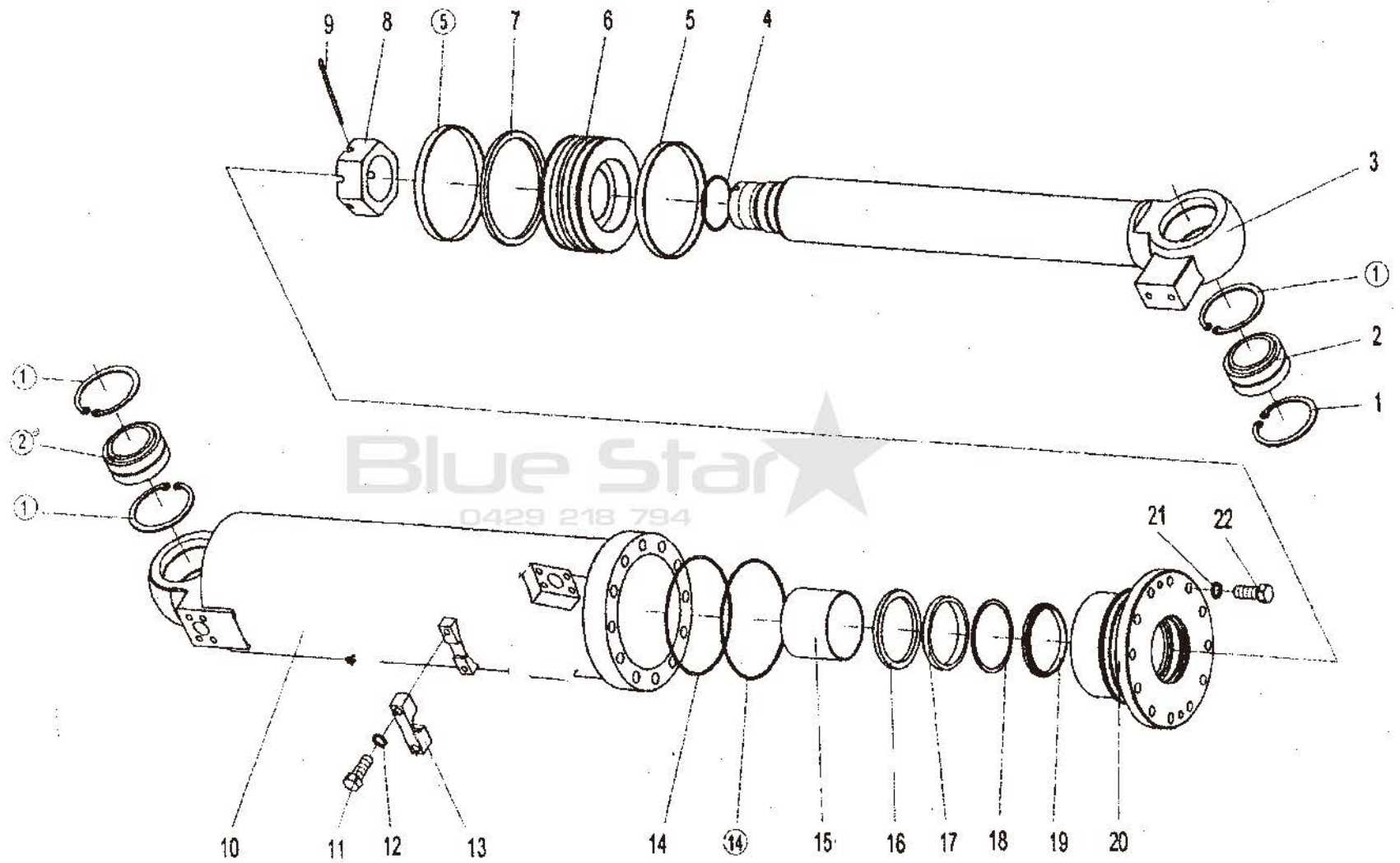

转斗油缸 Tilt Cylinder

序号 Ser. NO	零件名称 Part name		数量 Qty	零件代号 Part No
1	挡圈 90	Snap ring 90	4	GB893. 1-1986
2	关节轴承 GE60ES	Joint bearing GE60ES	2	GB304. 5-1981
3	活塞杆	Piston rod	1	ZL30F. 32. 2
4	O 形圈 70X3. 1	"O" ring 70x3. 1	1	GB1235-1976
5	支承环 D160Xd144X20	Support ring D160×d144X20	2	
6	活塞	Piston	1	ZL30F. 32-1
7	组合滑环 ZHQD160	Combined slide ring ZHQD160	1	
8	槽形螺母 M64X2	Slot nut M64x2	1	GB6178-1986
9	开口销 8X90	Split pin 8x90	1	GB91-1986
10	缸体	Cylinder block	1	ZL30F. 32. 1
11	螺栓 M10X40	Bolt M10x40	2	GB5783-1986
12	垫圈 10	Washer 10	2	GB93-1987
13	压板	Set plate	1	ZL30F. 32-2
14	O 形圈 160X5. 7	"O" ring 160×5. 7	2	GB1235-1976
15	复合轴承	Combined bearing	1	SF-1
16	组合滑环 ZHQd90	Combined slide ring ZHQd90	1	
17	派克密封圈	seal ring of parker	1	B3 9005 P5008
18	挡圈 d90XD102X2	Snap ring d90xD102x2	1	
19	防尘圈 D90Xd102X11	Dust ring D90xd102x11	1	
20	导向套	Guide sleeve	1	ZL30F. 32-3
21	螺栓 M16X45	Bolt M16×45	12	GB5783-2000
22	垫圈 16	Washer 16	12	GB93-1987

举升油缸 Lifting Cylinder

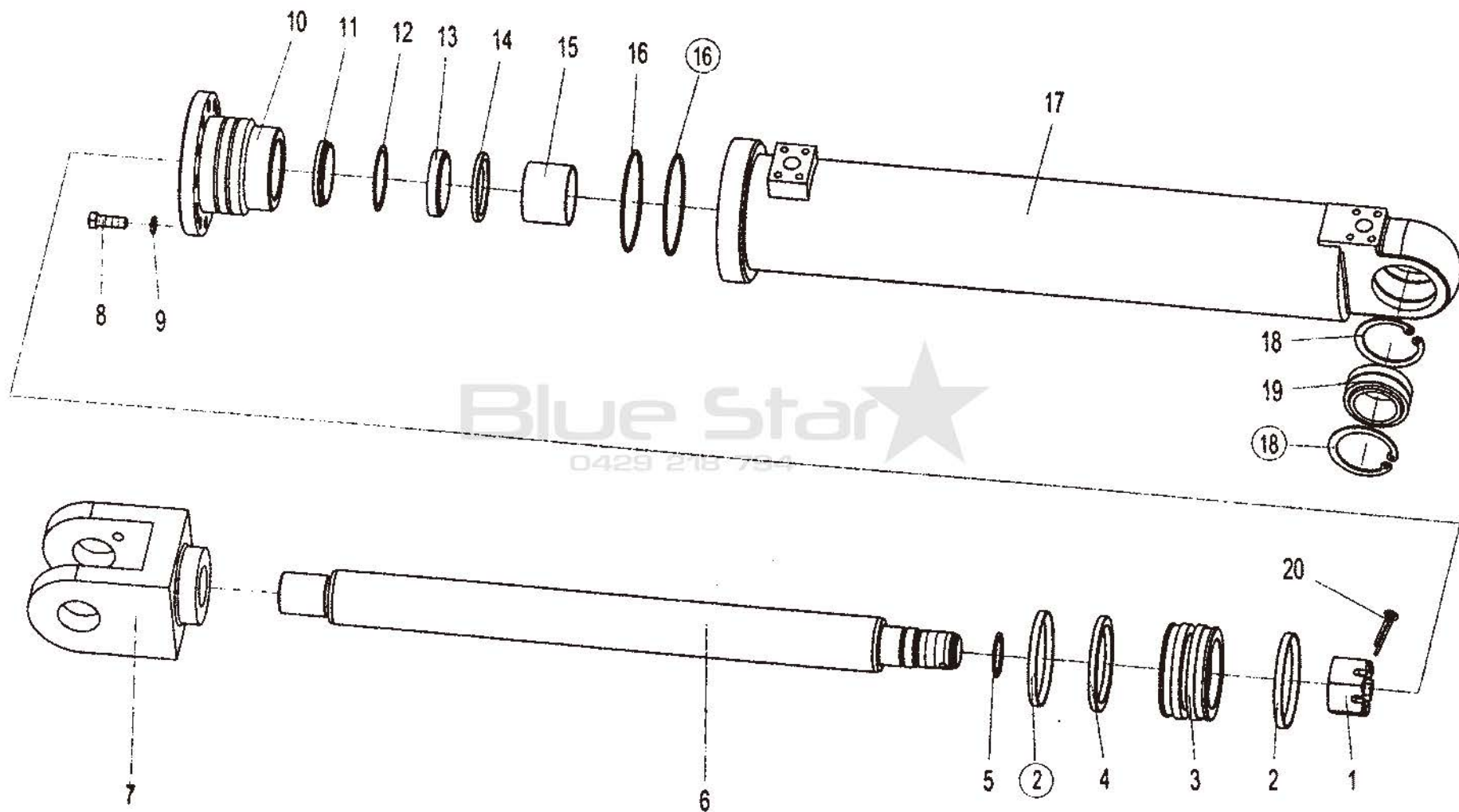

举升油缸 Lifting Cylinder

序号 Ser. NO	零件名称 Part name		数量 Qty	零件代号 Part No
1	槽形螺母 M27X1.5	Slot nut M27×1.5	1	GB6178-1986
2	支承环	Support ring D80xd75×9.5	2	
3	活塞	Piston	1	ZL30F.31-1
4	组合滑环 ZHQD110	Combined slide ring ZHQD110	1	
5	O形圈 45X3.1	"O" ring 45×3.1	1	GB1235-1976
6	活塞杆	Piston rod	1	ZL30F.31-2
7	叉头	Forked head	1	ZL30F.31-4
8	螺栓 M12X35	Bolt M12×35	12	GB5783-2000
9	垫圈 12	Washer 12	12	GB93-1987
10	导向套	Guide sleeve	1	ZL30F.31-3
11	防尘圈 D75Xd63X11	Dust ring D75×d63×11	1	
12	挡圈 D75Xd63X2	Snap ring D75×d63×2	1	
13	派克密封圈	seal ring of parker	1	BS 6378 P5008
14	组合滑环 ZHQd63	Combined slide ring ZHQd63	1	
15	复合轴承	Combined bearing	1	SF-1
16	O形圈 110X3.1	"O" ring 110×3.1	2	GB1235-1976
17	缸体	Cylinder block	1	ZL30F.31.1
18	挡圈 75	Snap ring 75	2	GB893.1-1986
19	关节轴承 GE50ES	Joint bearing GE50ES	1	GB304.5-1981
20	开口销 8X80	Split pin 8x80	1	GB91-1986

工作装置总成 Working Equipment Assembly

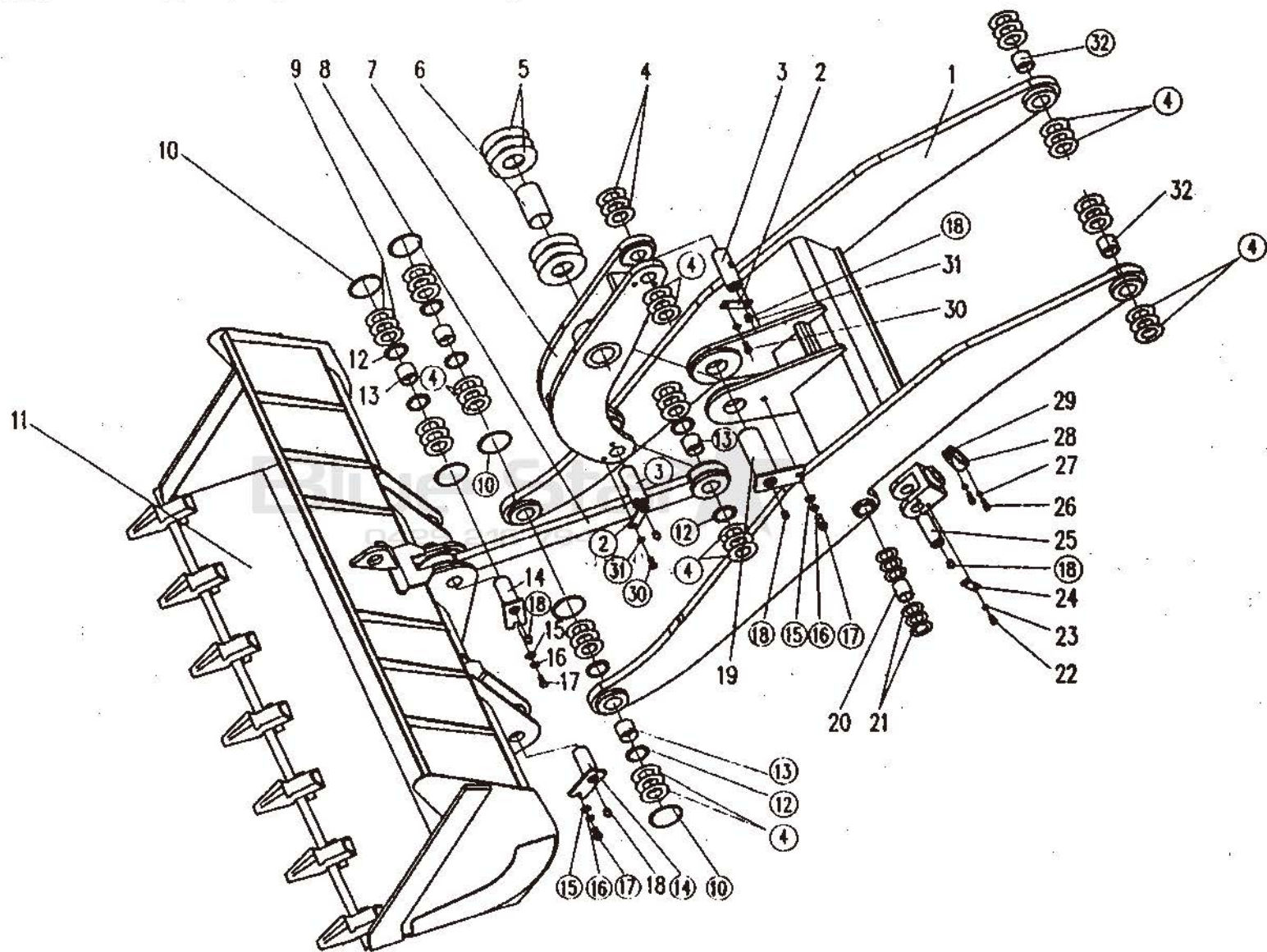

工作装置总成 Working Equipment Assembly

序号 Ser. No	零件名称 Part Name	数量 Qty	零件代号 Part No
1	30 加长动臂 (2950)	Lift arm	1
	30 超长动臂 (3200)	Lift arm	1
2	定轴板	Positioning plate	2
3	销轴	Pin	2
4	调整垫 I $\delta 1$	Adjusting spacer	12
	调整垫 I $\delta 1.5$	Adjusting spacer	12
	调整垫 I $\delta 2$	Adjusting spacer	6
5	调整垫 III $\delta 1$	Adjusting spacer	2
	调整垫 III $\delta 1.5$	Adjusting spacer	2
	调整垫 III $\delta 2$	Adjusting spacer	1
6	摇臂衬套	Bush	1
7	摇臂	Rocker arm	1
8	加长拉杆	Linkage rod	1
	超长拉杆	Linkage rod	1
9	调整垫 II $\delta 1$	Adjusting spacer	2
	调整垫 II $\delta 1.5$	Adjusting spacer	2
	调整垫 II $\delta 2$	Adjusting spacer	1
10	密封圈	Seal ring	6
11	30 标准斗	Bucket	1
	30 装沙王斗	Bucket	1
	30 岩石斗	Bucket	
	30 装煤斗 (2.5方)	Bucket	
12	防尘圈	Dust ring	8
13	衬套 I	Bush	4
14	销轴总成	Pin	3
15	平垫圈 20	Washer	4

工作装置总成 Working Equipment Assembly

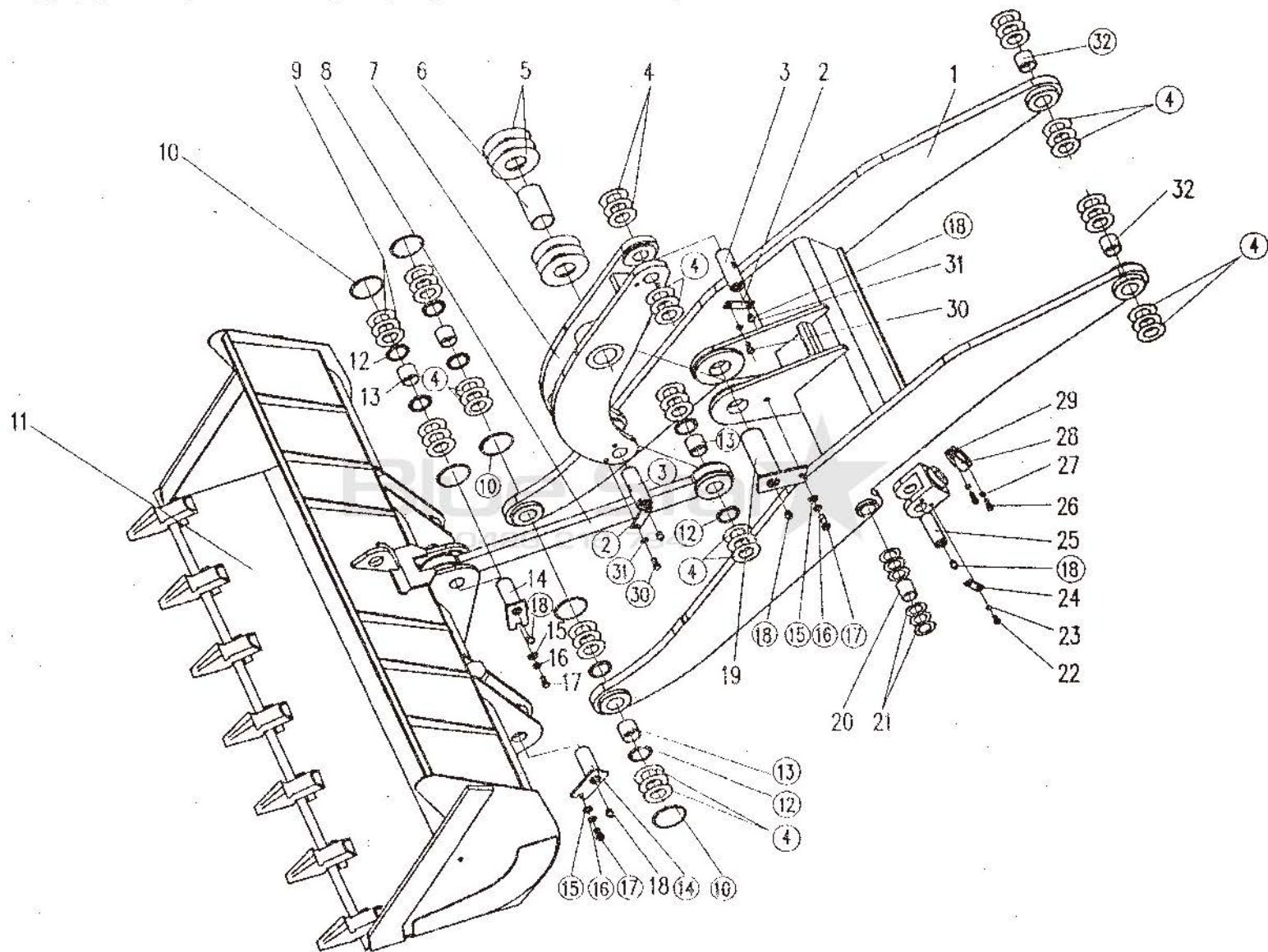

工作装置总成 Working Equipment Assembly

序号 Ser. No	零件名称 Part Name	数量 Qty	零件代号 Part No
16	垫圈 20	Washer	4
17	螺栓 M20×35	Bolt M20×35	4
18	油杯 M10×1	Oil cup M10×1	8
19	摇臂轴	Rocker arm of pin	1
20	衬套 II	Bush	2
21	调整垫 IV δ 1	Adjusting spacer	4
	调整垫 IV δ 1.5	Adjusting spacer	4
	调整垫 IV δ 2	Adjusting spacer	2
22	螺栓 M12×25	Bolt M12×25	4
23	垫圈 12	Washer 12	4
24	定轴板	Positioning plate	2
25	销轴	Pin	2
26	螺钉 M8×35 (仅超长臂用)	Bolt M8×35	4
27	垫圈 8 (仅超长臂用)	Washer 8	4
28	举升缸限位块 I (仅超长臂用)	Block, lifting cylinder I	2
29	举升缸限位块 II (仅超长臂用)	Block, lifting cylinder II	2
30	螺栓 M16×35	Bolt M16×35	4
31	垫圈 16	Washer 16	4
32	衬套 III	Bush	2

前车架总成 Front frame assembly

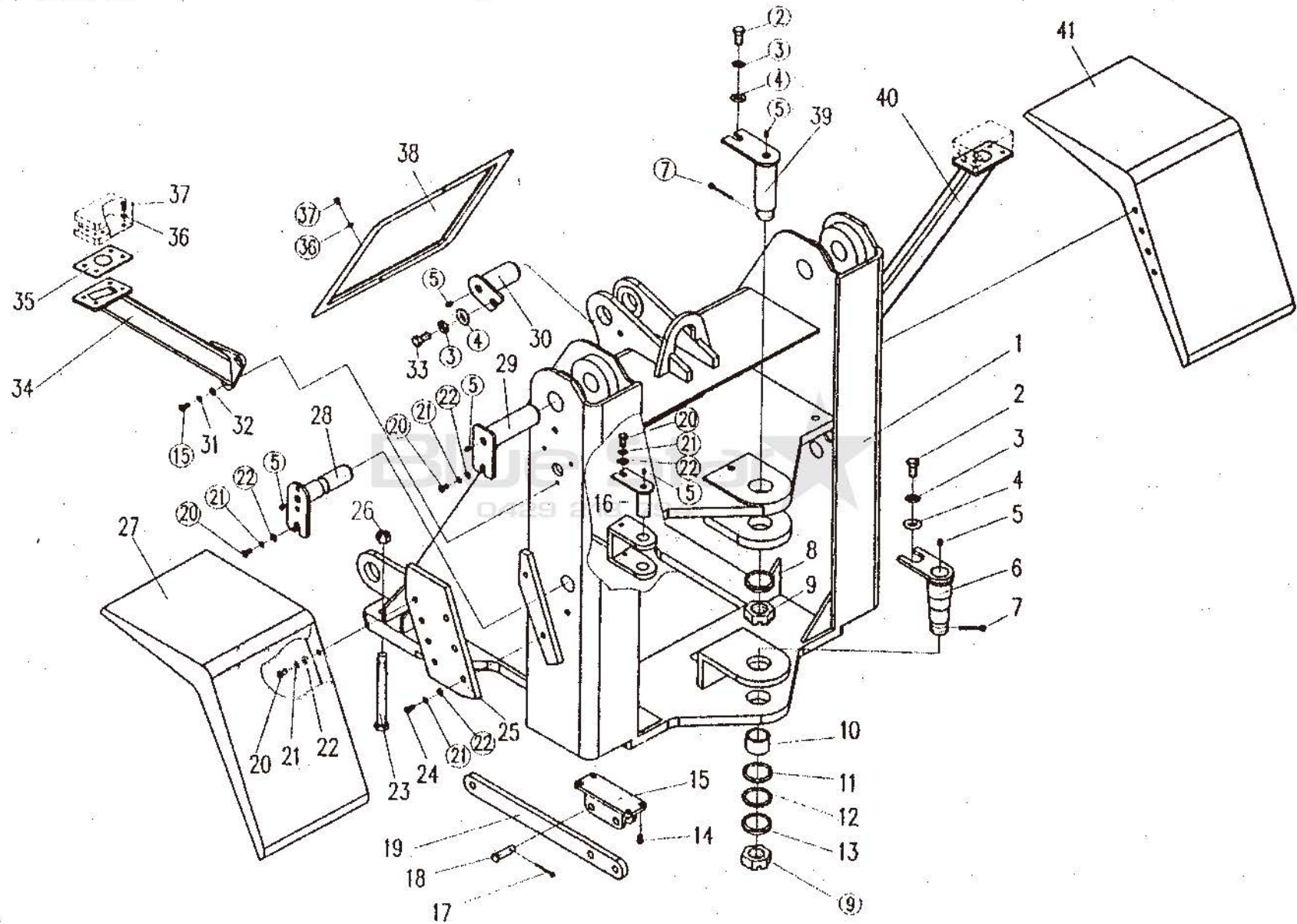

前车架总成 Front frame assembly

序号 Ser. No	零件名称 Part Name		数量 Qty	零件代号 Part No
1	前车架	Front frame	1	
2	螺栓 M20x40	Bolt M20x40	2	GB5783-86
3	垫圈 20	Washer 20	3	GB93-87
4	垫圈 20	Washer 20	3	GB95-85
5	油杯 M10x1	Oil cup M10x1	9	GB1152-79
6	销轴总成	Pin asy	1	
7	销 8x90	Pin 8x90	2	GB91-86
8	上垫	Upper washer	1	
9	螺母	Nut	2	
10	轴套	Bush	1	
11	调整垫 $\delta 0.05$	Adjusting shim $\delta 0.05$	1	
12	调整垫 $\delta 0.1$	Adjusting shim $\delta 0.1$	1	
13	垫	Washer	1	
14	螺栓 M10x30	Bolt M10x30	10	GB5783-86
15	锁止座	Lock up base	1	
16	转向销轴总成	Steering pin asy	2	
17	销 6.3x30	Pin 6.3x30	2	GB91-86
18	插销	Bolt	2	
19	锁止杆	Lock pole	1	
20	螺栓 M16x30	Bolt M16x30	14	GB5783-86
21	垫圈 16	Washer 16	20	GB93-87
22	垫圈 16	Washer 16	20	GB97.1-85
23	螺栓 M24x240	Bolt M24x240	8	GB5782-86
24	螺栓 M16x40	Bolt M16x40	6	GB5783-86

前车架总成 Front frame assembly

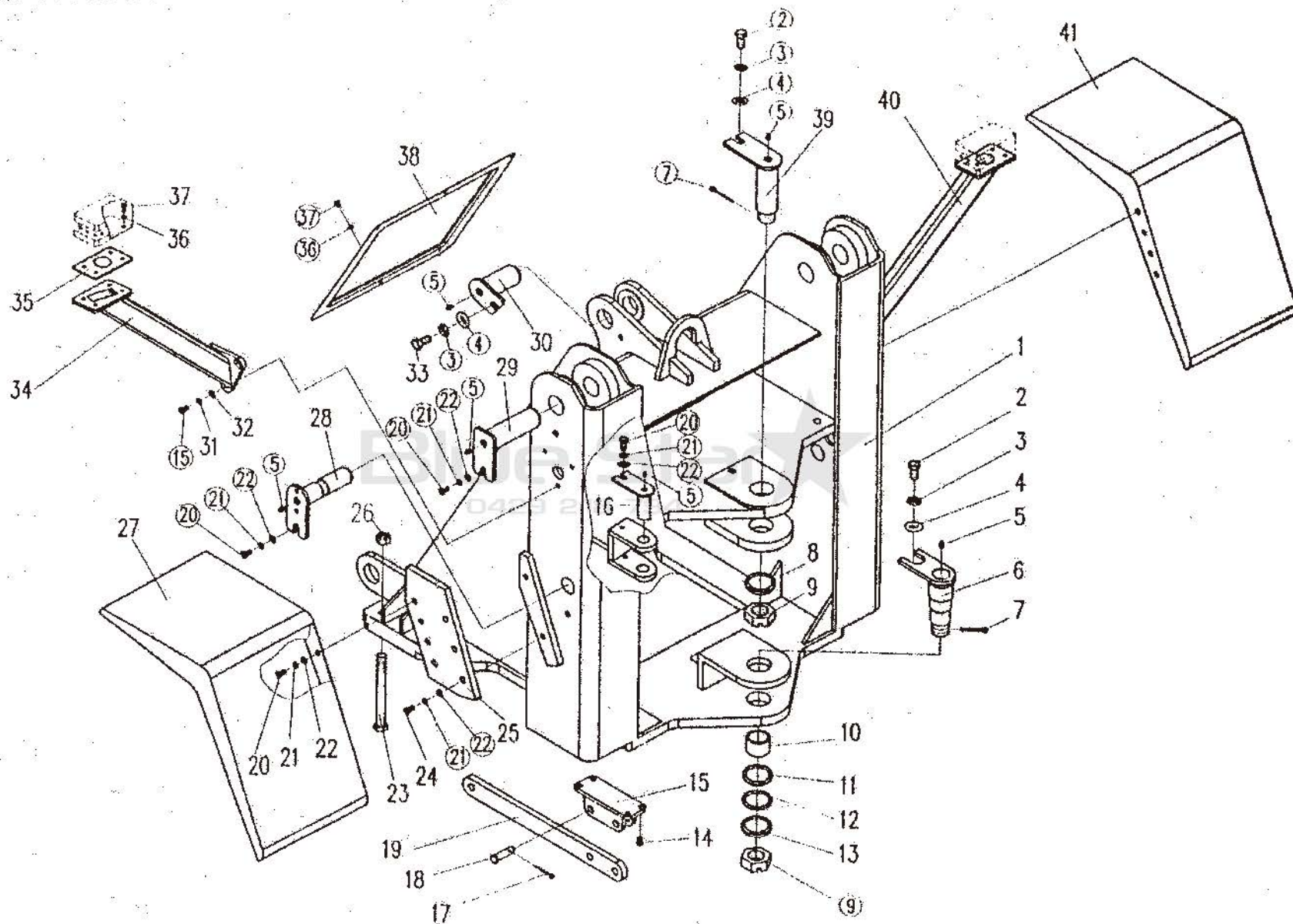

前车架总成 Front frame assembly

序号 Ser. No	零件名称 Part Name		数量 Qty	零件代号 Part No
25	联板 (左)	Connected board	1	
	联板 (右)	Connected board	1	
26	尼龙锁紧螺母 M24	Nylon lock nut M24	8	GB889-86
27	前挡泥瓦总成(左)	F/mud guard (L)	1	
28	举升缸销轴	Lift cylinder pin	2	
29	动臂后销轴	R/pin, lint cylinder	2	
30	翻斗缸后销轴	R/pin, tilt cylinder	1	
31	垫圈 10	Washer 10	6	GB93-87
32	垫圈 10	Washer 10	6	GB97.1-85
33	螺栓 M20x35	Bolt M20x35	1	GB5783-86
34	前灯架(左)	Front Camp bracket (L)	1	
35	垫板	Cushion	2	
36	垫圈 8	Washer 4	14	GB93-87
37	螺栓 M8x16	Bolt M8x16	14	GB5783-86
38	小盖板	Cover	1	
39	上铰接销轴	Upper joint pin	1	
40	前灯架(右)	Front Camp bracket (R)	1	
41	前挡泥瓦总成(右)	F/mud guard(R)	1	

后车架总成 Rear frame assembly

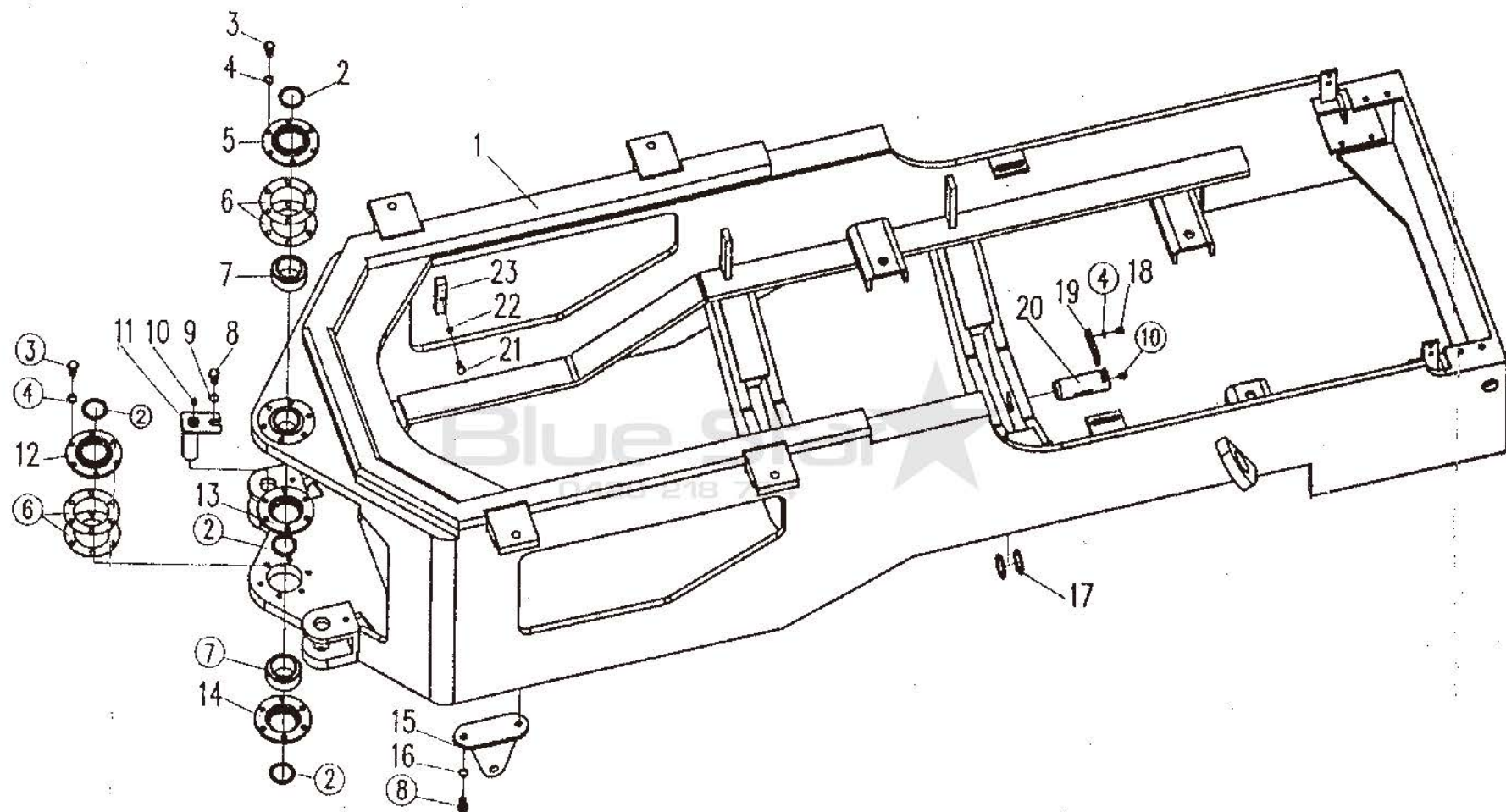

后车架总成 Rear frame assembly

序号 Ser. No	零件名称 Part Name		数量 Qty	零件代号 Part No
1	后车架	Rear frame	1	
2	密封圈	Seal ring	4	
3	螺栓 M12x25	Bolt M12x25	24	GB5783-86
4	垫圈 12	Washer 12	28	GB93-87
5	轴承盒	Bearing cage	1	
6	调整垫 δ 0.05	Adjusting shim δ 0.05	2	
	调整垫 δ 0.1	Adjusting shim δ 0.1	2	
	调整垫 δ 0.3	Adjusting shim δ 0.3	2	
	调整垫 δ 0.5	Adjusting shim δ 0.5	2	
7	关节轴承 GE60ES	Joint bearing	2	GB304.5-85
8	螺栓 M16x35	Bolt M16x35	4	GB5783-86
9	垫圈 16-100HV	Washer 16-100HV	2	GB95-85
10	油杯 M10x1	Oil cup M10x1	2	GB1152-79
11	转向销轴总成	Steering pin asy	2	
12	轴承盒	Bearing cage	1	
13	轴承盖	Bearing cover	1	
14	轴承盖	Bearing cover	1	
15	支座	Support	1	
16	垫圈 16	Washer 16	2	GB93-87
17	调整垫 δ 1	Adjusting shim δ 1	2	
	调整垫 δ 1.5	Adjusting shim δ 1.5	2	
	调整垫 δ 2	Adjusting shim δ 2	2	
18	螺栓 M12x25	Bolt M12x25	4	GB5783-86
19	定轴板	Set plate	2	
20	销轴	Pin	2	

后车架总成 Rear frame assembly

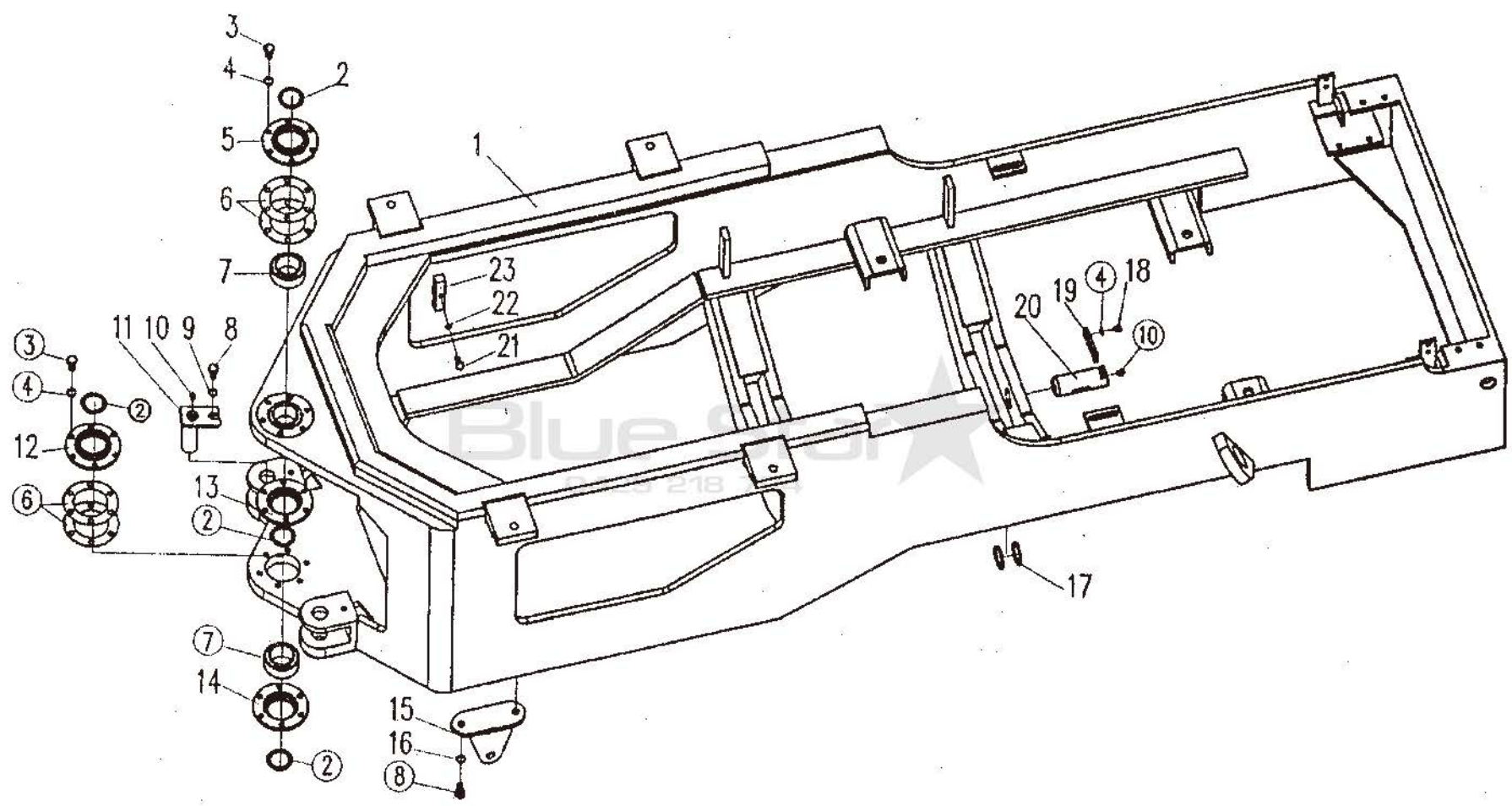

后车架总成 Rear frame assembly

序号 Ser. No	零件名称 Part Name		数量 Qty	零件代号 Part No
21	螺栓 M10x60	Bolt M10x60	2	GB5782-86
22	垫圈 12	Washer 12	2	GB95-85
23	油管卡	Clip	2	



摆动架总成 Oscillating frame assembly

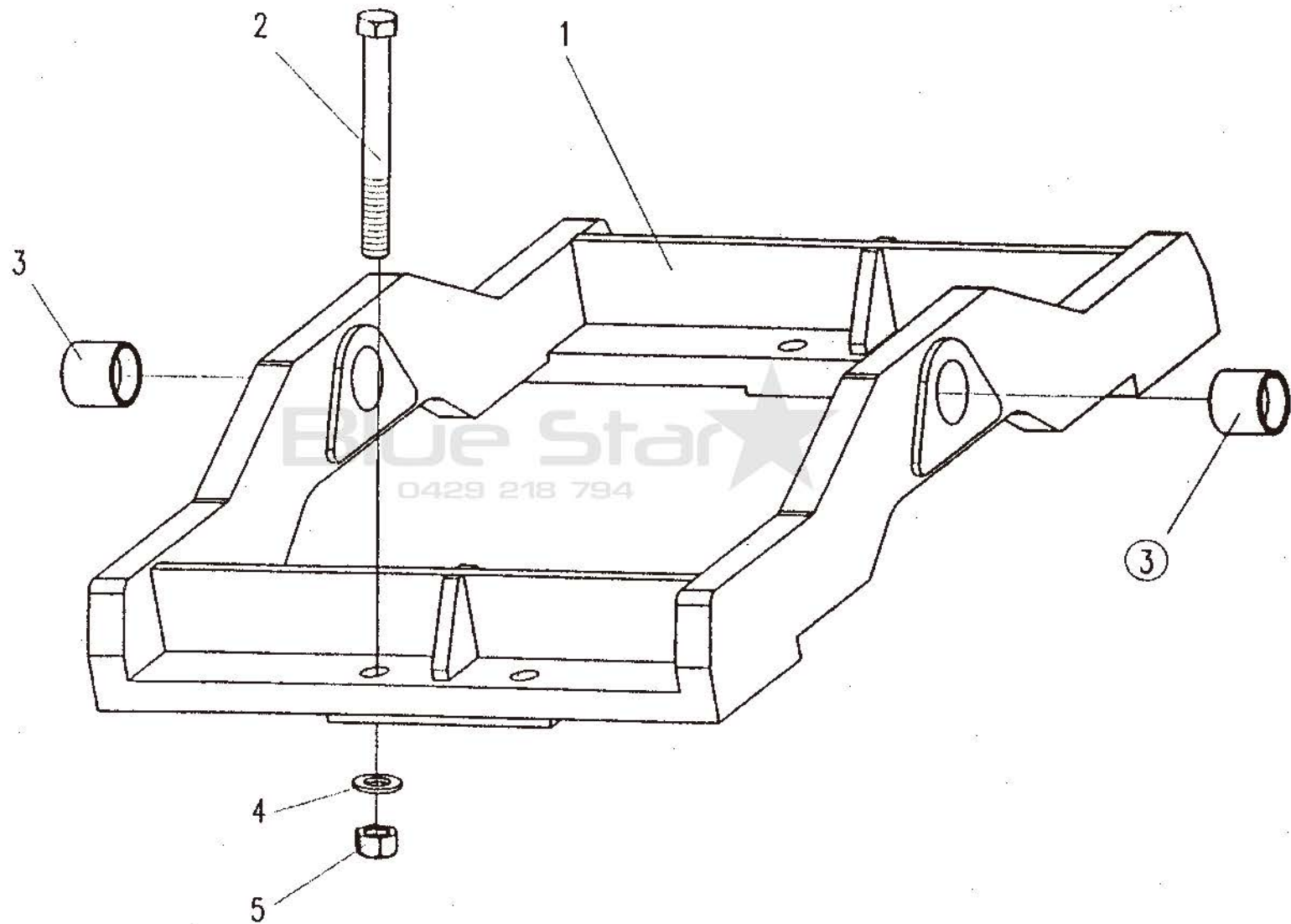

摆动架总成 Oscillating frame assembly

序号 Ser. No	零件名称 Part Name		数量 Qty	零件代号 Part No
1	下摆架	Lower oscillating frame	1	
2	螺栓 M24x220	Bolt M20x220	8	GB5782-86
3	摆动架衬套	Bush	2	
4	垫圈 24	Washer 24	8	GB97.1-85
5	螺母 M24	Nut M24	8	GB889-86



配重铁总成 Counterweight assembly

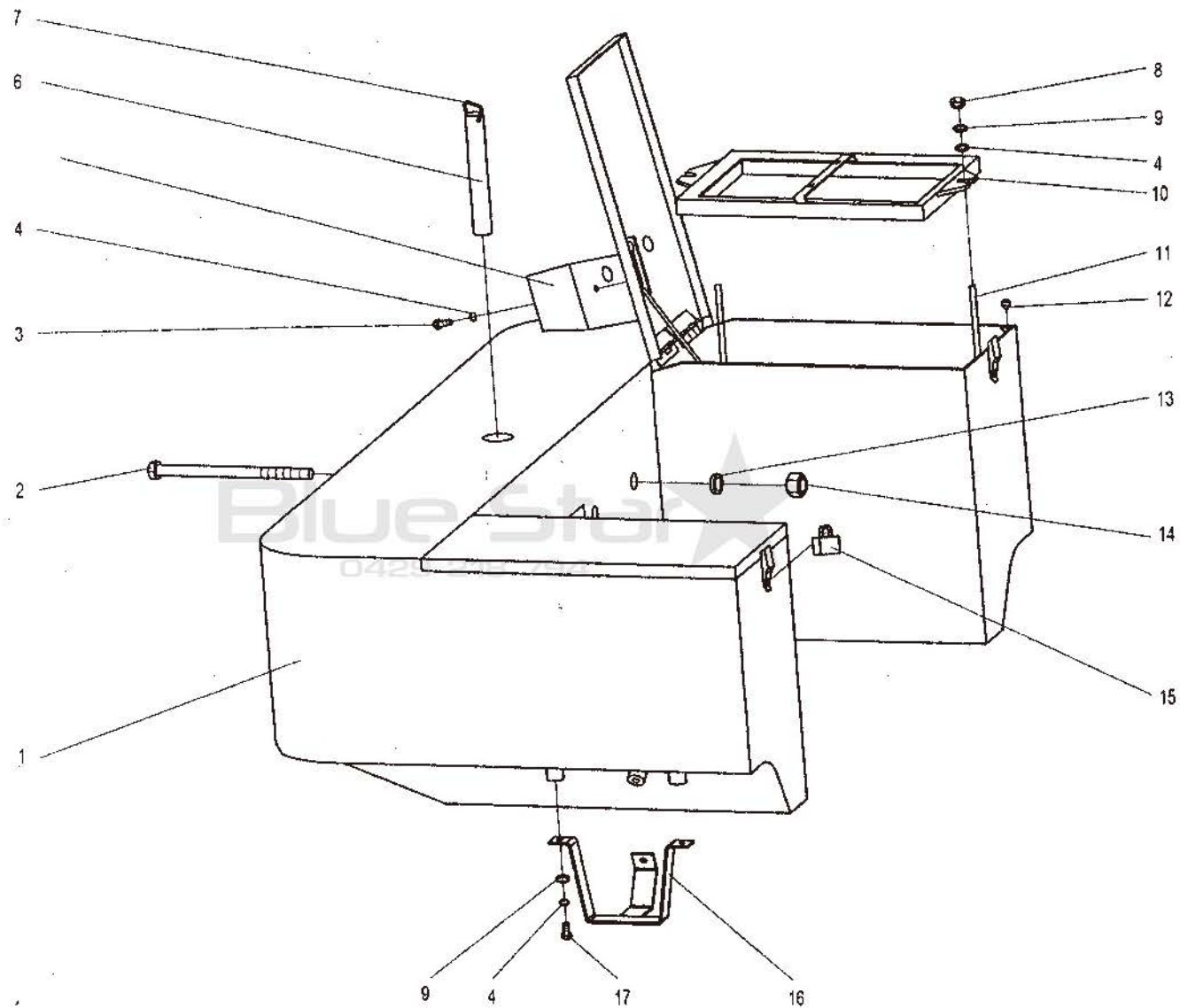

配重铁总成 Counterweight assembly

序号 Ser. No	零件名称 Part Name		数量 Qty	零件代号 Part No
1	配重铁	counterweight	1	
2	螺栓 M30×270	Bolt M30×270	2	
	螺栓 M20×280	Bolt M20×280	2	
3	螺栓 M10×20	Bolt M10×20	4	GB5783-86
4	弹簧垫圈 10	Lockwasher10	14	GB93-87
5	灯罩总成	Light frame	2	
6	拖车销	Tow pin	1	
7	提把	Handle	1	
8	螺母 M10-6	Nut M10-6	4	GB6170-86
9	平垫圈 10	Plain washer 10	10	GB97.1-85
10	压框总成	Set plate(right)	1	
11	压紧螺柱	Clamping bolt	4	
12	减震垫	Damping gasket	8	
13	弹簧垫圈 30	Lockerwasher 30	4	GB93-87
14	螺母 M30	Nut M30	4	GB6170-86
15	小挂锁	Small lock	2	
16	脚踏	Pedal	2	
17	螺栓 M10×25	Bolt M10×25	6	

标尺总成 Ruler Assembly

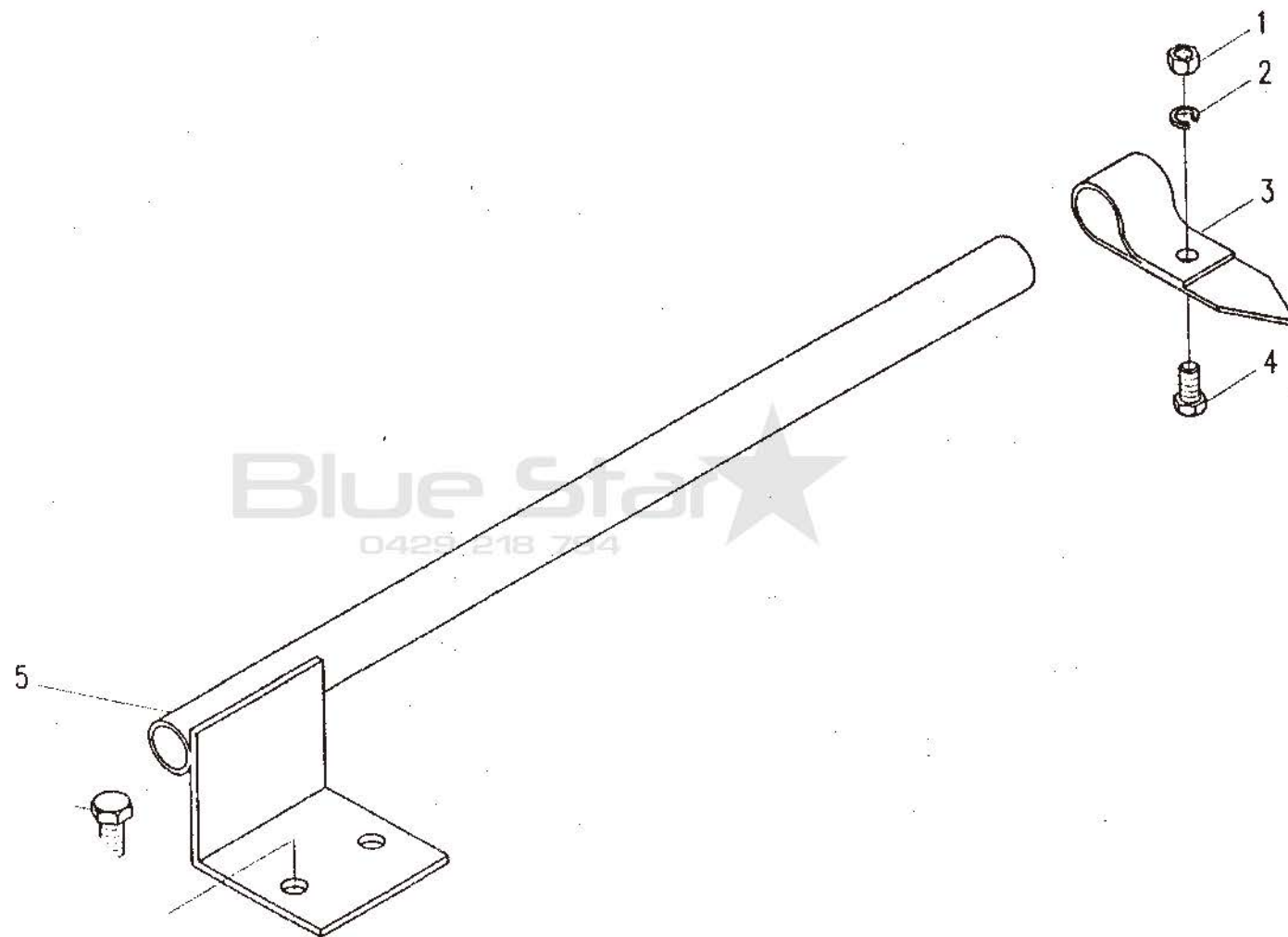

Blue Star
0425 218 734

标尺总成 Ruler Assembly

序号 Ser. No	零件名称 Part Name		数量 Qty	零件代号 Part No
1	螺母 M8	Nut M8	1	GB6170-86
2	垫圈 8	Washer 12	1	GB93-87
3	箭头	Arrowhead	1	
4	螺栓 M8x16	Bolt M8x16	1	GB5781-86
5	标尺	Ruler	1	
6	螺栓 M10x20	Bolt M10x20	2	GB5781-86
7	垫圈 10	Washer 10	2	GB93-87



左右侧地板总成 L/R Side floor

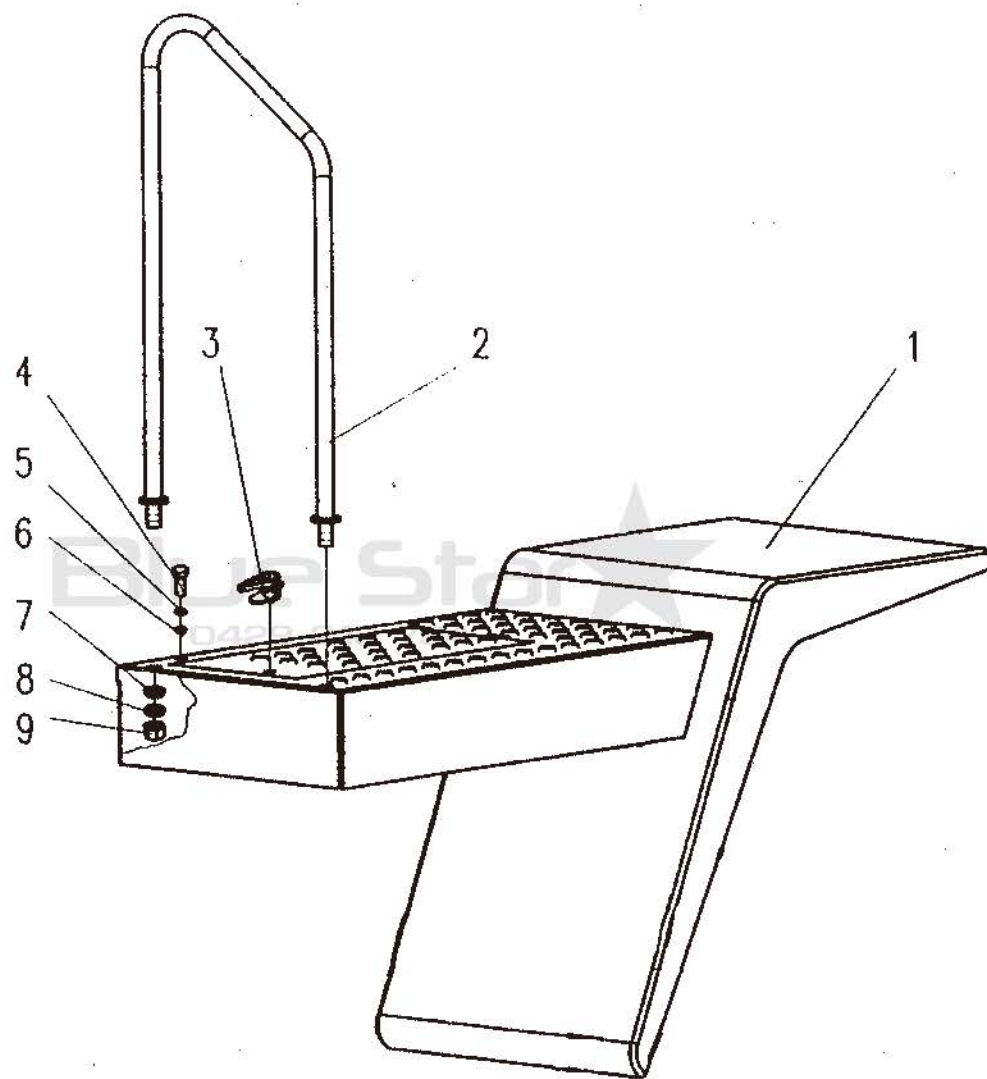

左右侧地板总成 L/R Side floor

序号 Ser. No	零件名称 Part Name	数量 Qty	零件代号 Part No
1	左侧地板 L/Side floor	1	
	右侧地板 R/Side floor	1	
2	前扶手总成 Front handrail	1	
3	锁止把总成 Lockup handle assembly	1	
4	螺栓 M12x30 Bolt M12x30	4	GB5783-2000
5	垫圈 12 Washer 12	4	GB93-87
6	垫圈 12 Washer 12	4	GB97.1-2002
7	垫圈 16 Washer 16	4	GB97.1-2002
8	垫圈 16 Washer 16	4	GB93-87
9	螺母 M16-6 Nut M16-6	4	GB6170-2000

柴油箱总成 Fuel Tank Assembly

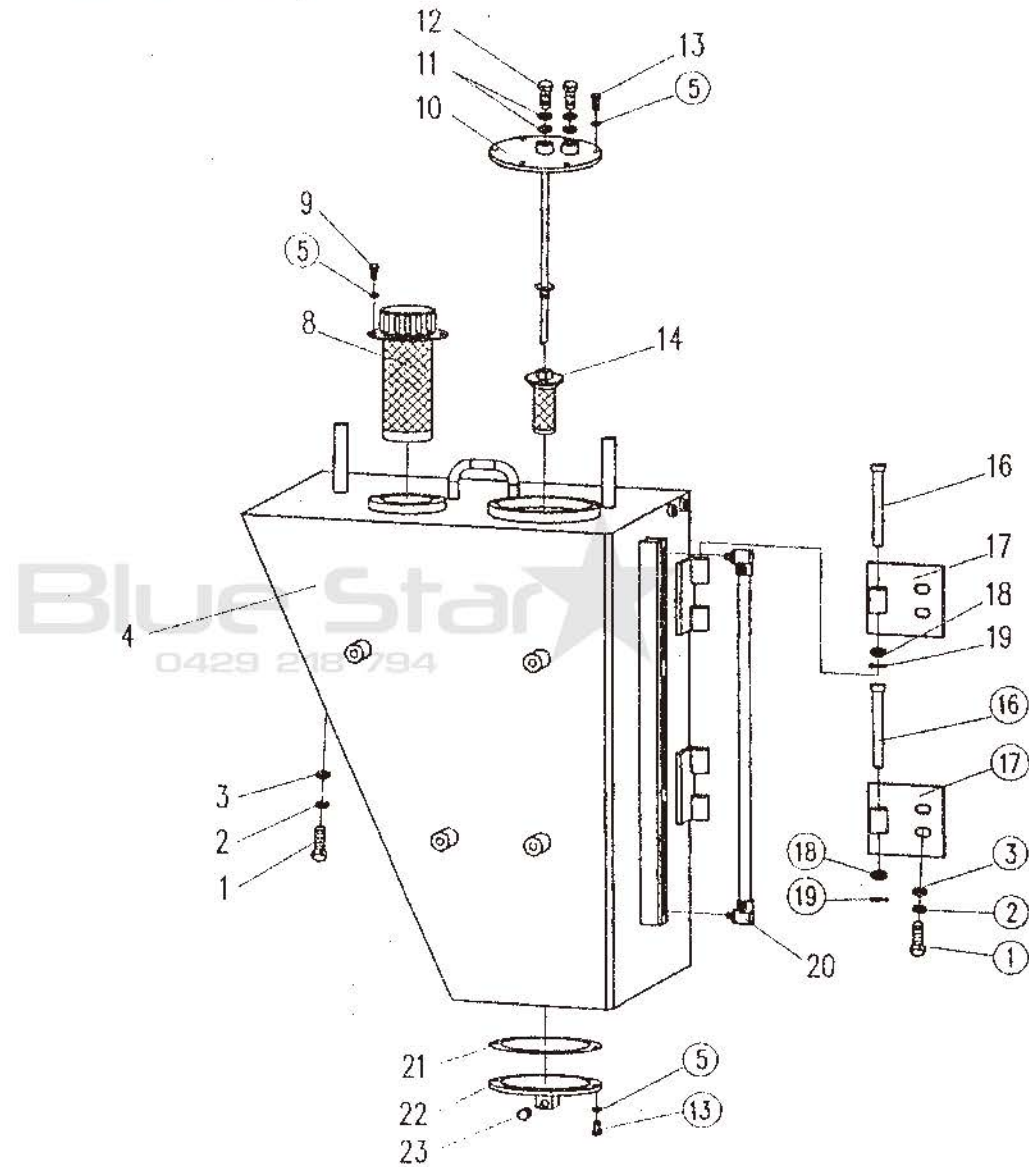

柴油箱总成 Fuel Tank Assembly

序号 Ser. No	零件名称 Part Name		数量 Qty	零件代号 Part No
1	螺栓 M14x30	Bolt M14x30	6	GB5783-86
2	垫圈 14	Washer 14	6	GB93-87
3	垫圈 14	Washer 14	6	GB97.1-85
4	柴油箱箱体	Oil-tank block	1	
5	垫圈 8	Washer 8	12	GB95-85
8	加油滤油器	Oil filler screen	1	
9	螺栓 M8x12	Bolt M8x12	4	GB5783-86
10	吸回油口总成	Oil-suction return port assembly	1	
11	垫圈 A14	Washer A14	4	JB982-77
12	螺栓 M14x1.5x32	Bolt M14x1.5x32	2	JB999.6-77
13	螺栓 M8x20	Bolt M8x20	12	GB5783-86
14	吸油滤网	Oil-suction screen	1	
16	连接轴	Subordinating	2	
17	连接铰接合叶	Annuitant	2	
18	垫圈 16	Washer 16	2	GB97.1-85
19	开口销 2x30	Split pin 2x30	2	GB91-86
20	液位计	Oil indicator	1	
21	密封垫	Sealing spacer	1	
22	清洗口法兰	Cleaning port flange	1	
23	放油阀芯	Oil release valve spool	1	

机油箱总成 Engine Oil Tank Assembly

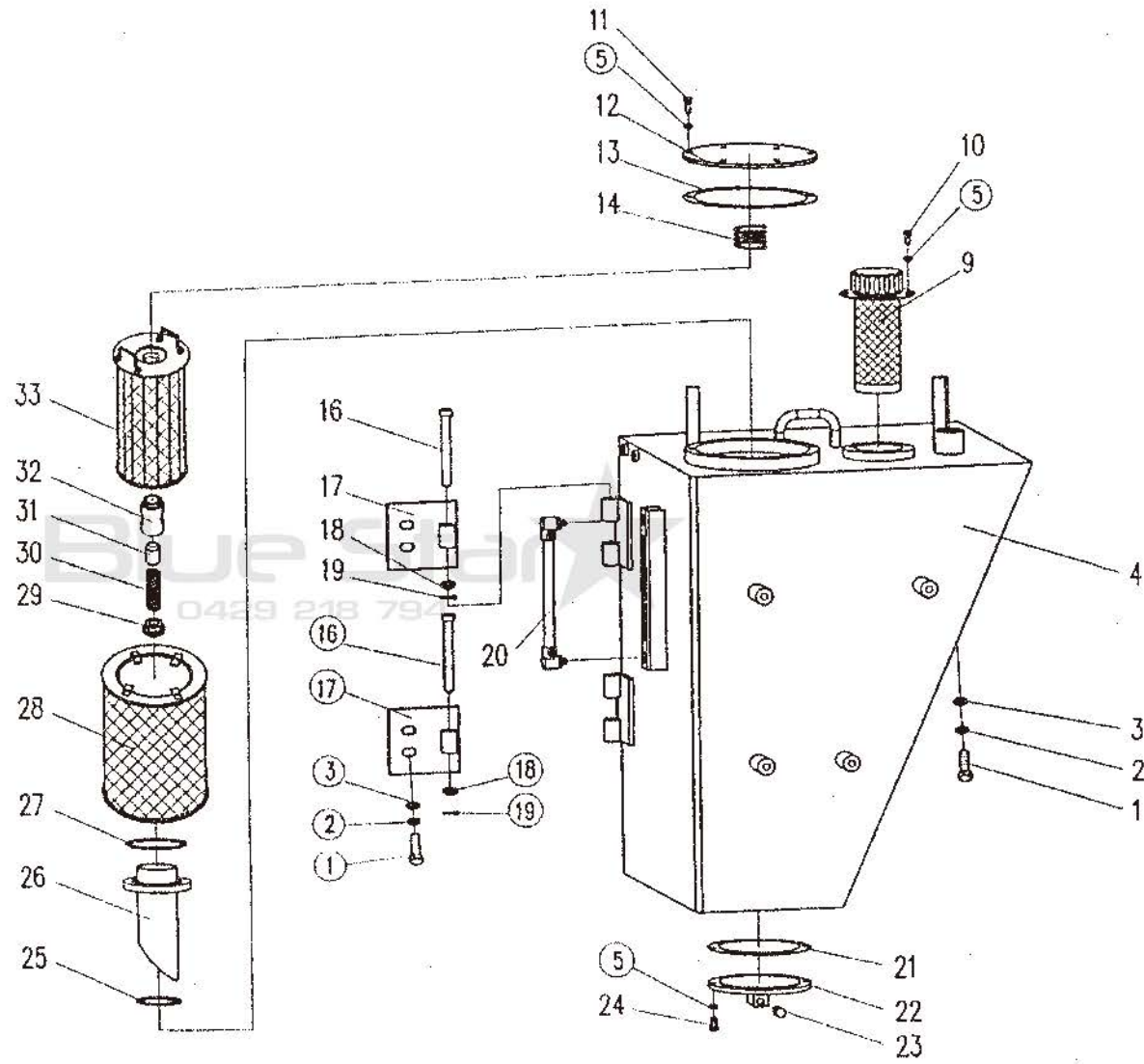

机油箱总成 Engine Oil Tank Assembly

序号 Ser. No	零件名称 Part Name		数量 Qty	零件代号 Part No
1	螺栓 M14x30	Bolt M14x30	6	GB5783-86
2	垫圈 14	Washer 14	6	GB93-87
3	垫圈 14	Washer 14	6	GB97.1-85
4	机油箱箱体	Oil tank	1	
5	垫圈 8	Washer 8	18	GB95-85
9	加油滤油器 SFM-323K	Oil filler screen	1	
10	螺栓 M8x12	Bolt M8x12	4	GB5783-86
11	螺栓 M8x25	Bolt M8x25	8	GB5783-86
12	滤油器盖	Filter cover	1	
13	耐油胶垫 237x175x2.4	Oil resistant spacer 237x175x2.4	1	JB87-59
14	弹簧	Spring	1	
16	连接轴	Subordinating	2	
17	连接铰接合叶	Anne tent	2	
18	垫圈 16	Washer 16	2	GB97.1-85
19	开口销 2x30	Split pin 2x30	2	GB91-86
20	液位计	Oil indicator	1	
21	密封垫	Sealing spacer	1	
22	清洗口法兰	Cleaning port flange	1	
23	放油阀芯	Oil release valve spool	1	
24	螺栓 M8x20	Bolt M8x20	6	GB5783-86
25	O型圈 75.5x3.55	O-ring 75.5x3.55	1	GB3452.1-82
26	滤油器出口	Outlet	1	
27	O型圈 110 x 3.1	O-ring 110 x 3.1	1	GB1235-79

机油箱总成 Engine Oil Tank Assembly

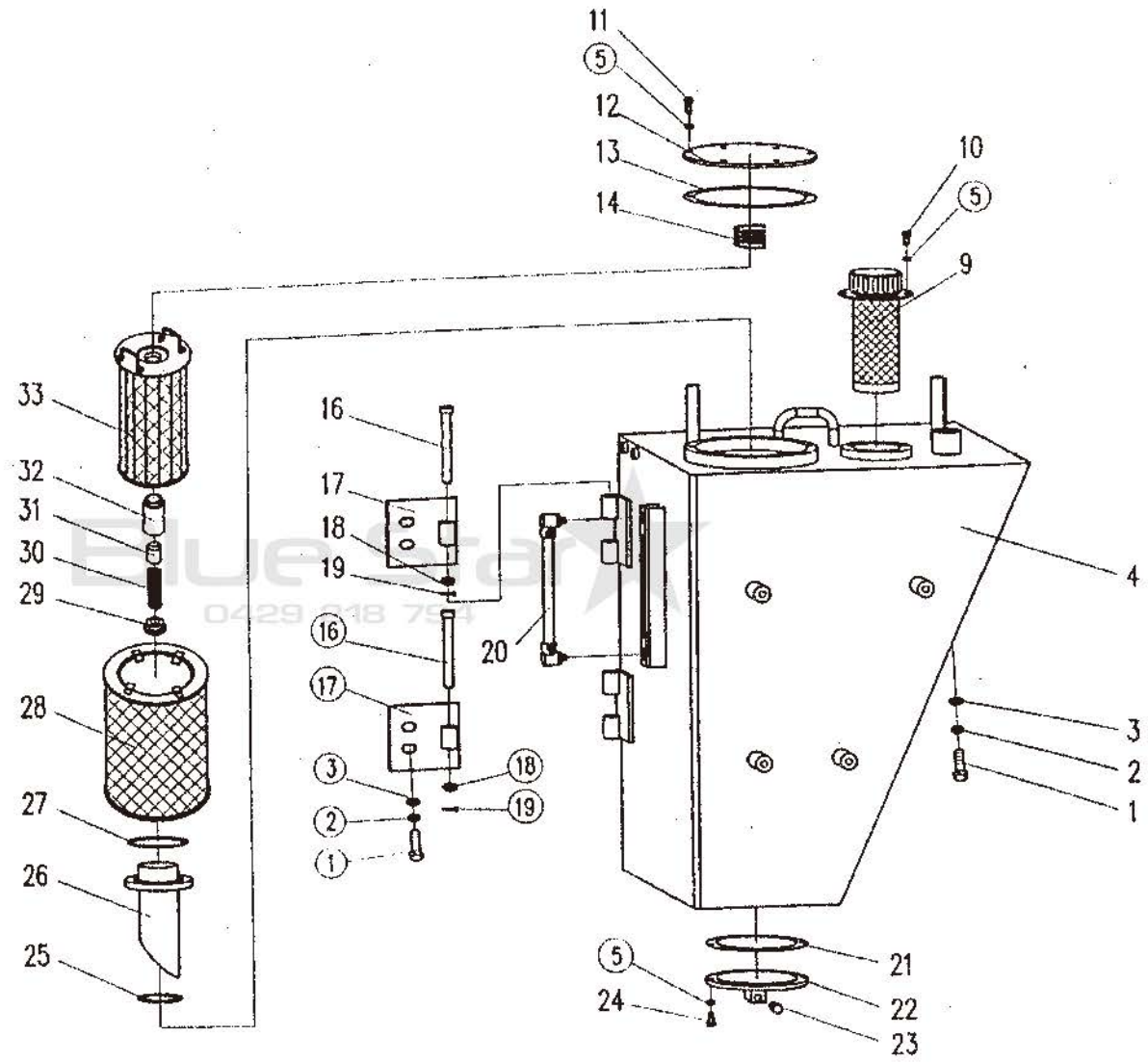

机油箱总成 Engine Oil Tank Assembly

序号 Ser. No	零件名称 Part Name		数量 Qty	零件代号 Part No
28	外层滤网	Outer screen	1	
29	弹簧座	Retainer	1	
30	弹簧	Spring	1	
31	滑阀	Valve spool	1	
32	旁通阀体	Sideway valve	1	
33	内层滤网	Inner screen	1	



发动机罩总成 Engine Hood Assembly

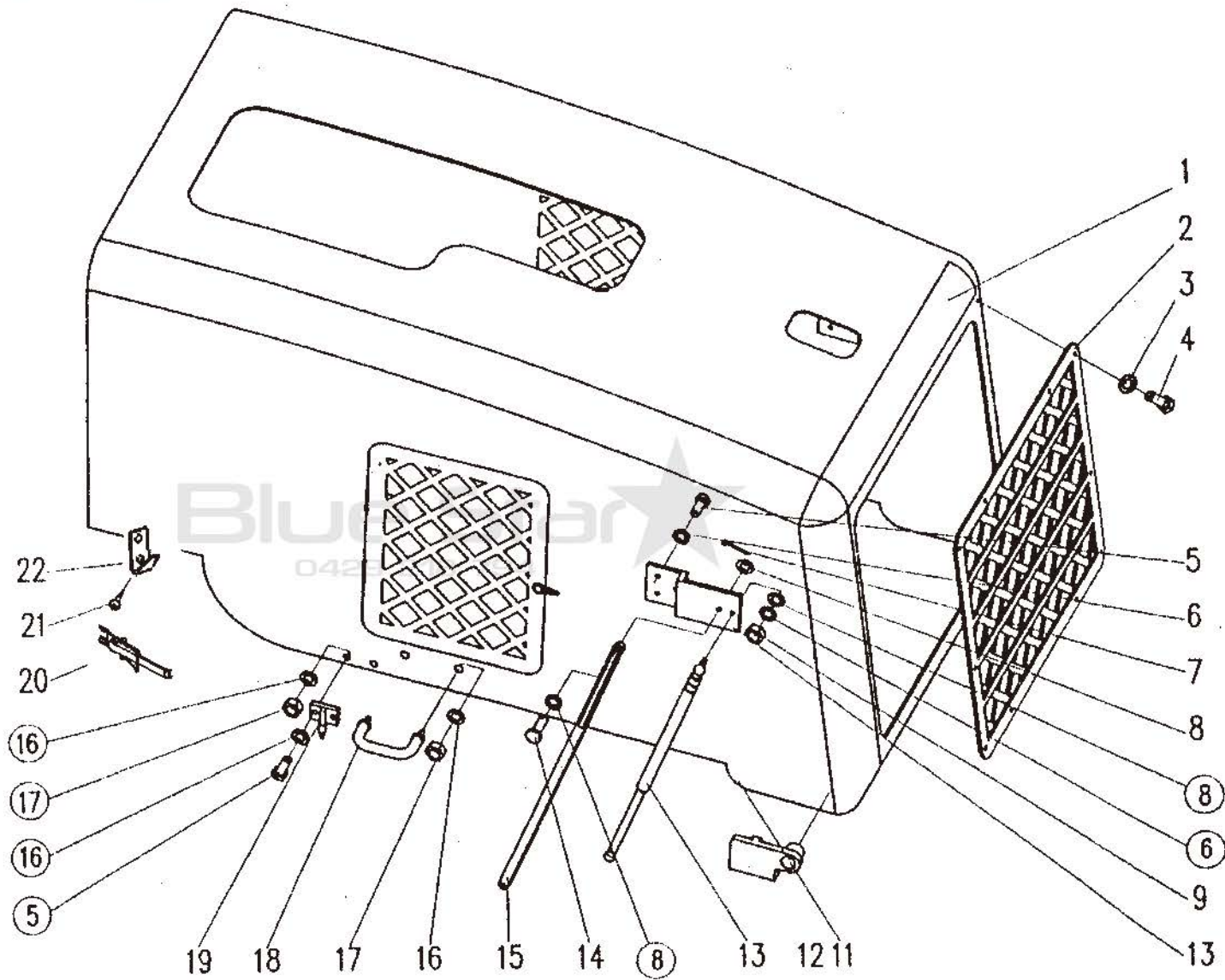

发动机罩总成 Engine Hoodl Assembly

序号 Ser. No	零件名称 Part Name	数量 Qty	零件代号 Part No
1	发动机罩	1	
2	防护网	1	
3	垫圈 8	10	GB95-85
4	螺栓 M8x60	10	GB5783-86
5	螺栓 M10x20	16	GB5783-86
6	垫圈 8	6	GB93-87
7	开口销 2.5X18	4	GB91-86
8	垫圈 8	1	GB95-85
9	螺母 M8	4	GB889-86
10	气弹簧支座	2	
11	罩子支座 (左)	1	
12	罩子支座 (右)	1	
13	气弹簧	2	
14	销轴 M8x35	2	GB882-86
15	拉板	2	
16	垫圈 10	4	GB95-85
17	螺母 M10	4	GB6170-86
18	把手	2	
19	挡销组件	2	
20	挂鼻	2	
21	螺栓 M10x25	4	
22	挂钩	2	

转向操纵机构 Steering Control Mechanism

序号 Ser. No	零件名称 Part Name	数量 Qty	零件代号 Part No
1	喇叭按钮总成	1	
2	螺母 M16x1.5	1	GB6173-86
3	轴套	1	
4	喇叭继电器	1	
5	挡圈 20	1	GB894.1-86
6	调整垫	1	
7	轴承 104	1	GB276-89
8	转向管柱接头	1	
9	螺栓 M10x30	6	GB5783-86
10	垫圈 10	11	GB93-87
11	垫圈 10	5	GB95-85
12	管柱固定座	1	
13	转向管柱	1	
14	转向管柱下接头	1	
15	轴套	1	
16	固定环	1	
17	螺栓 M10x40	2	GB5783-86
18	管柱固定卡	1	
19	油杯 M10x1	1	GB1152-79
20	转向轴	1	
21	转向器固定板	1	
22	螺栓 M10x20	3	GB5783-86
23	方向盘	1	NJ130
		1	

变速箱操纵机构总成 Transmission Control Mechanism Assembly

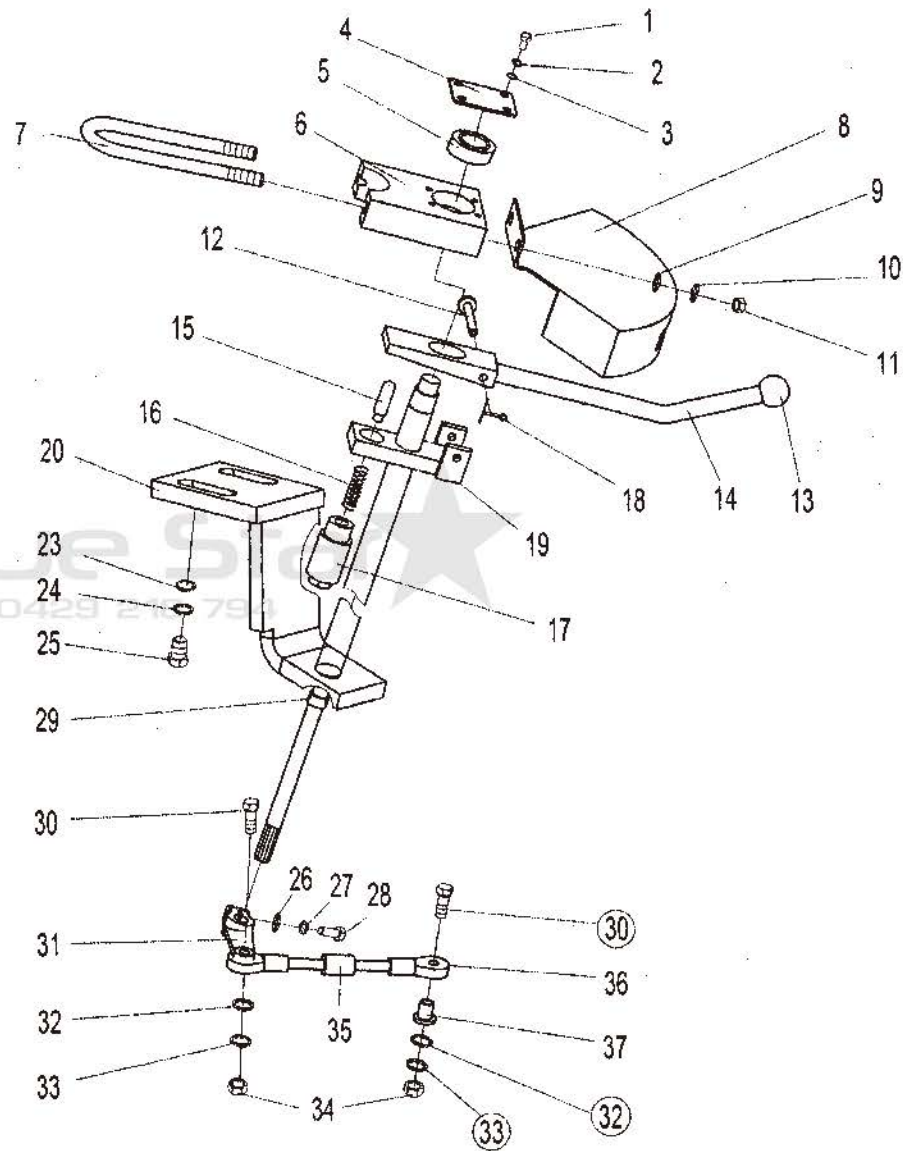

变速箱操纵机构总成 Transmission Control Mechanism Assembly

序号 No.	零件名称 Part Name	数量 Qty	零件代号 Part No	
1	螺栓 M5×10	BOLT M5×10	4	GB5781-86
2	垫圈 5	WASHER 5	4	GB93-87
3	垫圈 5	WASHER 5	4	GB97.1-85
4	小盖板	LITTLE COVER PLATE	1	
5	深沟球轴承	BEARING	1	GB276-89
6	上顶板	UPPER PLATE	1	
7	U形螺栓	"U" BOLT	1	
8	指示牌总成	INDICATOR BOARD ASSEMBLY	1	
9	垫圈 10	WASHER 10	4	GB93-87
10	垫圈 10	WASHER 10	4	GB97-85
11	螺母 M10	NUT M10	4	GB6170-86
12	销轴	PIN	1	
13	手柄	HANDLE	1	
14	操纵手柄总成	CONTROL HANDLE ASSEMBLY	1	
15	弹簧帽	SPRING CAP	1	
16	弹簧 1×10×36	SPRING 1×10×36	1	GB2089-80
17	弹簧座	SPRING SEAT	1	
18	开口销 1.5×20	PIN 1.5×20	1	GB91-86
19	转杆总成	SWITCH LEVER ASSEMBLY	1	
20	变速固定板	FASTNESS BLOCK	1	
21	垫圈 12	WASHER 12	2	GB93-87
22	垫圈 12	WASHER 12	2	GB95-85
23	螺栓 M12×30	BOLT M12×30	2	GB5783-86
24	垫圈 6	WASHER 6	2	GB93-87
25	垫圈 6	WASHER 6	3	GB97-85

变速箱操纵机构总成 Transmission Control Mechanism Assembly

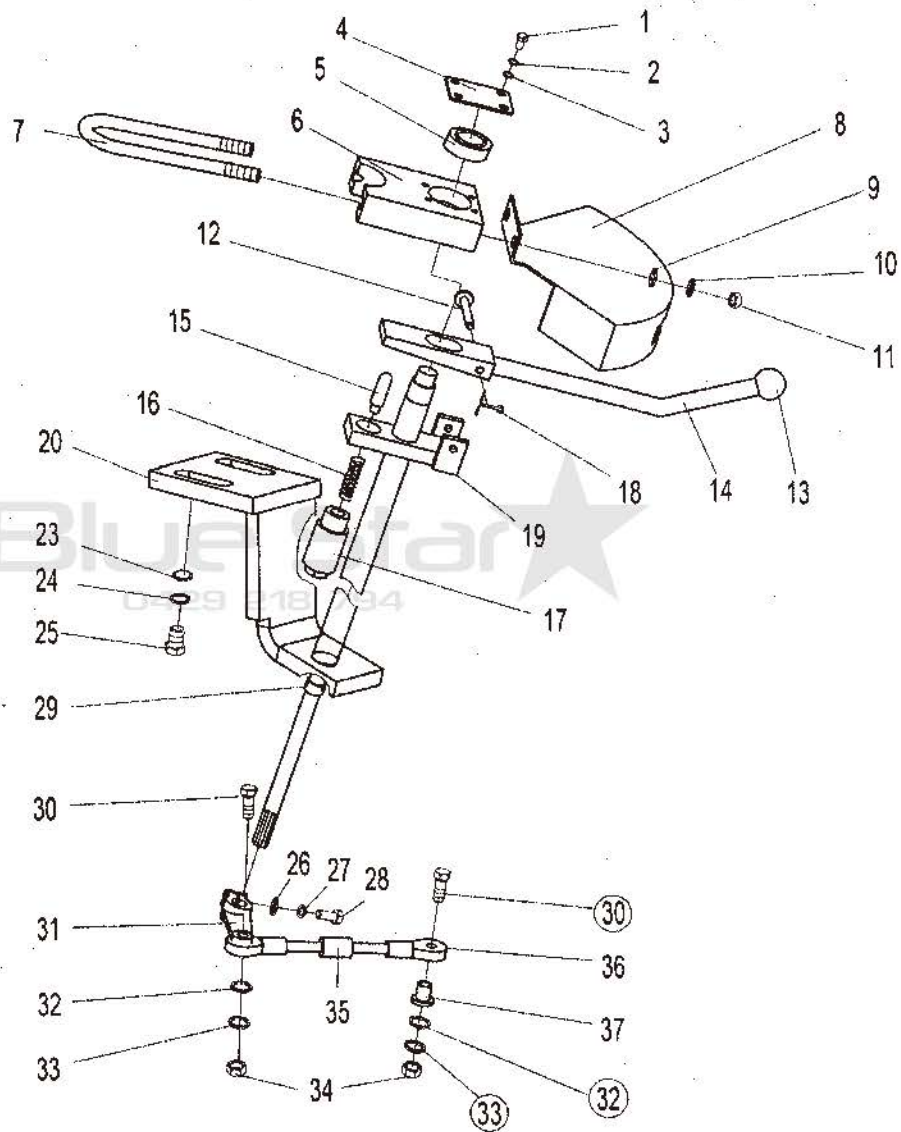

变速箱操纵机构总成 Transmission Control Mechanism Assembly

序号 Ser. No	零件名称 Part Name	数量 Qty	零件代号 Part No
26	螺栓 M6×20	2	GB5783-86
27	衬套	1	ZL30F. 7-6
28	轴承螺栓	2	ZL30F. 7-4
29	换向操纵摇臂	1	ZL50D. 8-21
30	垫圈 8	2	GB95-87
31	垫圈 8	2	GB97-85
32	螺母 M8		GB6170-86
33	拉杆		
34	关节轴承 S18E		GB4222-84
35	垫		ZL30F. 7-5



高低速工作阀操纵机构 H/L Speed Control Mechanism for working Valve Assembly

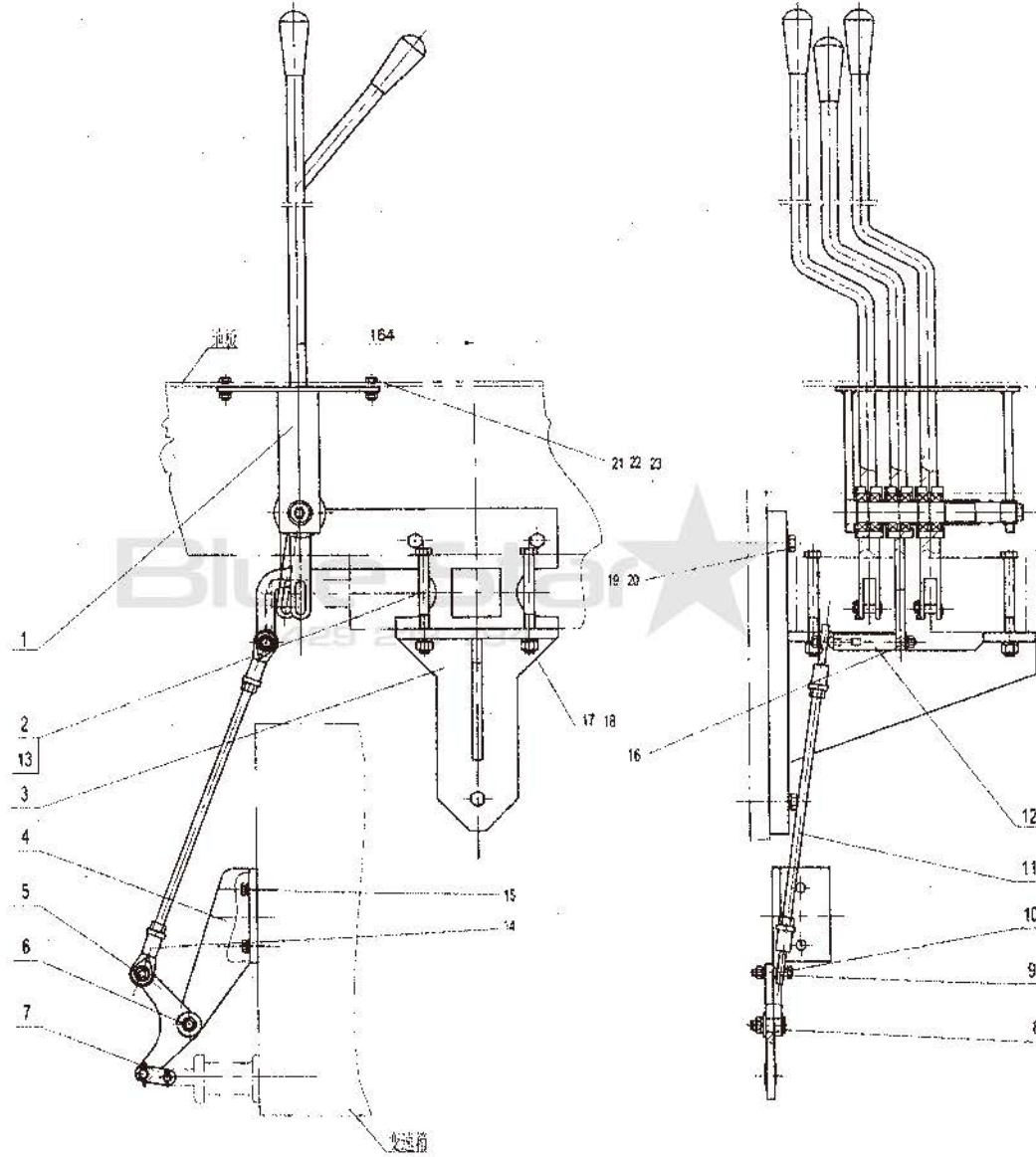

高低速工作阀操纵机构 H/L Speed Control Mechanism for working Valve Assembly

序号 Ser. No	零件名称 Part Name	数量 Qty	零件代号 Part No	
1	高低速工作阀操纵机构集成 (两联阀)	Control Mechanism Assembly	1	
2	高低速工作阀操纵机构集成 (三联阀)	Control Mechanism Assembly	1	
2	螺栓 M12×130	Bolt	4	
3	工作阀固定座 (两联阀)	The work valve fixs	1	
4	工作阀固定座 (三联阀)	The work valve fixs	1	
4	底座支架	Bottom bracket	1	
5	连接板 I	Connecting platr I	1	
6	垫片	Washer	1	
7	拉板	Connecting platr	2	
8	销轴	Pin shaft	1	
9	垫	Spacer	2	
10	轴承螺栓	Bearing bolt	2	
11	连接杆	Connecting rod	1	
12	连接轴	Connecting shaft	1	
13	螺栓 M12×140	Bolt	2	
14	关节轴承 S18E	Joint bearing S18E	2	GB4222-84
15	螺栓 M10x25	Bolt M10x25	2	GB5783-86
16	螺母 M10	Nut M10	1	GB6170-86
17	螺母 M12	Nut M12	4	GB6170-86
18	垫圈 12	Washer 12	4	GB93-87
19	螺栓 M16x35	Bolt M16x35	3	GB5781-86
20	垫圈 16	Washer 16	3	GB93-87
21	螺母 M8	Nut M8	4	GB6170-86
22	垫圈 8	Washer 8	3	GB93-87
23	螺栓 M8x30	Bolt M8x30	4	GB5781-86

地板与操纵台总成 Floor and control board Assembly

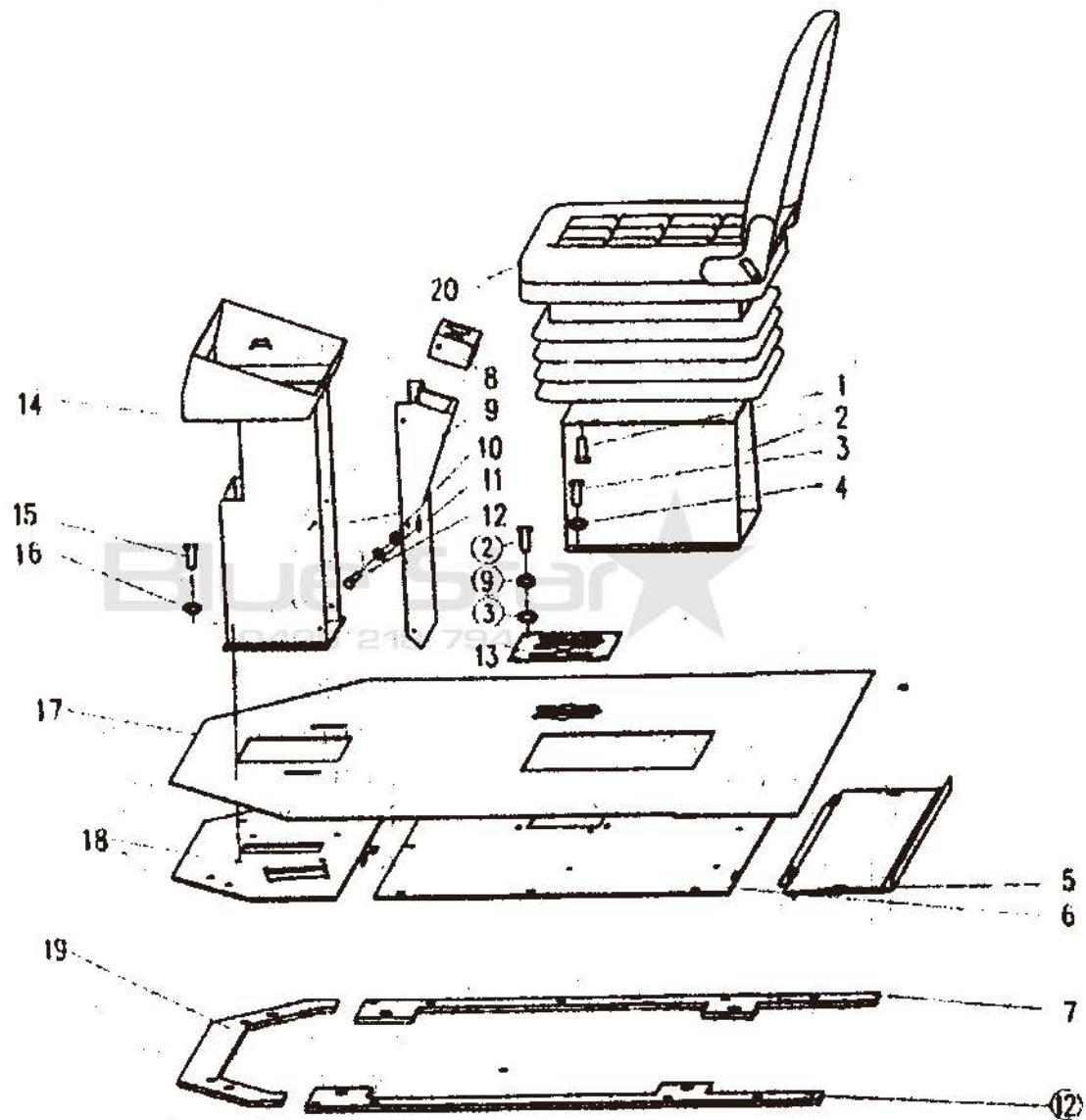

地板与操纵台总成 Floor and control board Assembly

序号 Ser. No	零件名称 Part Name		数量 Qty	零件代号 Part No
1	螺栓 M8x20	Bolt M8x20	4	GB5783-86
2	座椅底座	Base for seat	1	
3	螺栓 M8x30	Bolt M8x30	4	GB5783-86
4	垫圈 8	Washer 8	4	GB95-85
5	后地板组件	Behind floor module	1	
6	中地板	Middle floor	1	
7	侧垫板	Lateral cushiony plate	2	
8	上盖	Over Cover	1	
9	护罩	Hood	1	
10	垫圈 6	Washer 6	6	GB95-85
11	垫圈 6	Washer 6	6	GB93-87
12	螺钉 M6x12	Bolt M6x12	6	GB67-85
13	操纵杆盖板	Cover plate for control lever	1	
14	操纵台支架	Frame for control board	1	
15	螺栓 M12x25	Bolt M12x25	8	GB5783-86
16	垫圈 12	Washer 12	8	GB93-87
17	室内橡胶地板	Rubber floor	1	
18	前地板组件	Front floor module	1	
19	前垫板	Front cushiony plate	1	
20	座椅	Seat	1	

驾驶室总成 (一) Cab Assembly (One)

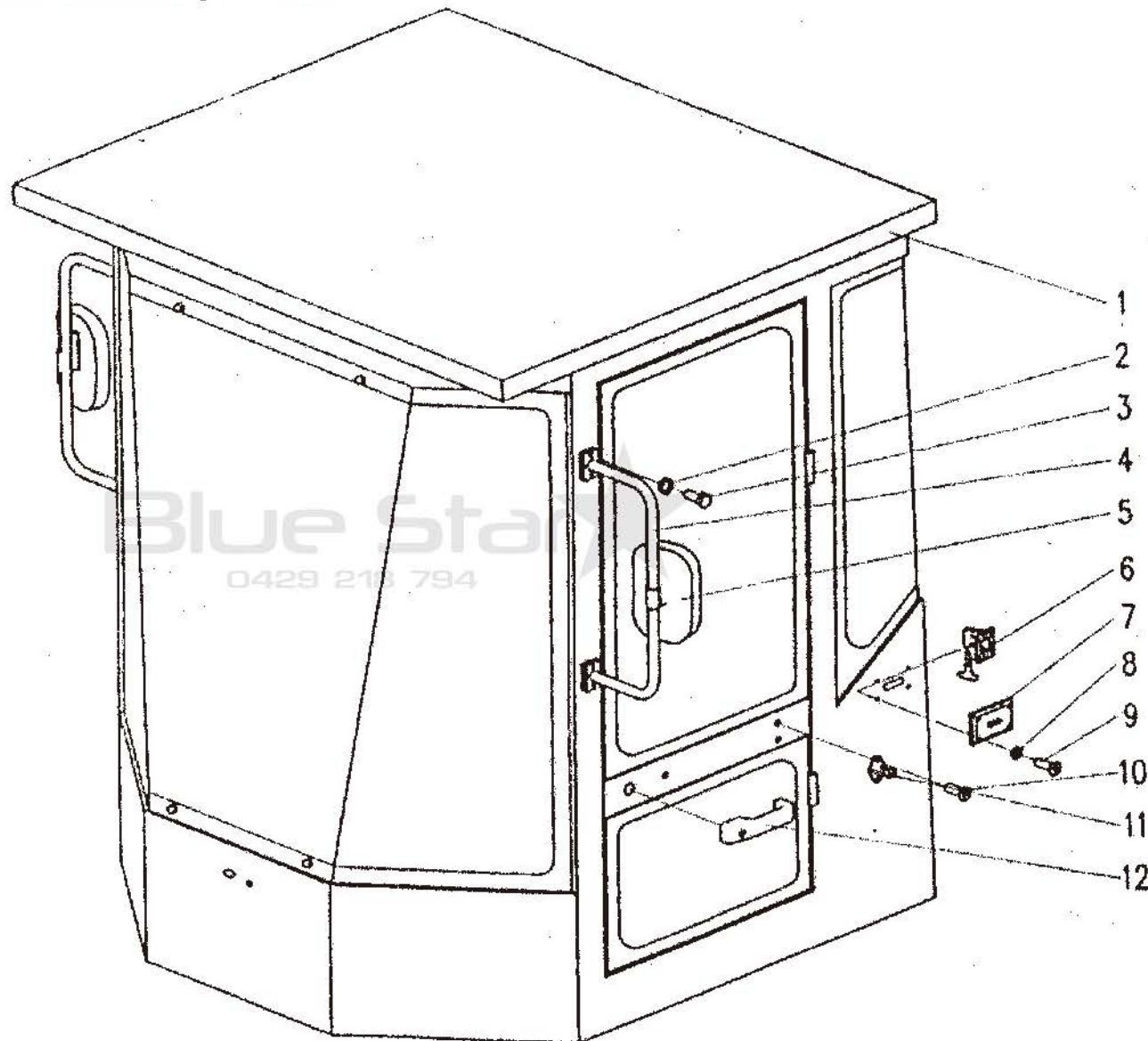

驾驶室总成 (一) Cab Assembly (One)

序号 Ser. No	零件名称 Part Name	数量 Qty	零件代号 Part No
1	驾驶室	Cab	1
2	垫圈 8	Washer 8	8
3	螺栓 M8x16	Bolt M8x16	8
4	后视镜支架	Reverse mirror	2
5	后视镜	Reverse mirror	1
6	锁止	Thru lock	1
7	护罩	Cover	1
8	螺钉 M4x10	Screw M4x10	8
9	垫圈 4	Washer 4	8
10	螺钉 M6x12	Screw M6x12	4
11	锁止钩	Catch For Thru lock	1
12	门锁 (左)	Lock	1
	门锁 (右)	Lock	1
13	内视镜	Reverse mirror	1
14	垫圈 6	Washer 6	2
15	螺栓 M6x20	Bolt M6x20	2

驾驶室总成 (二) Cab Assembly (Two)

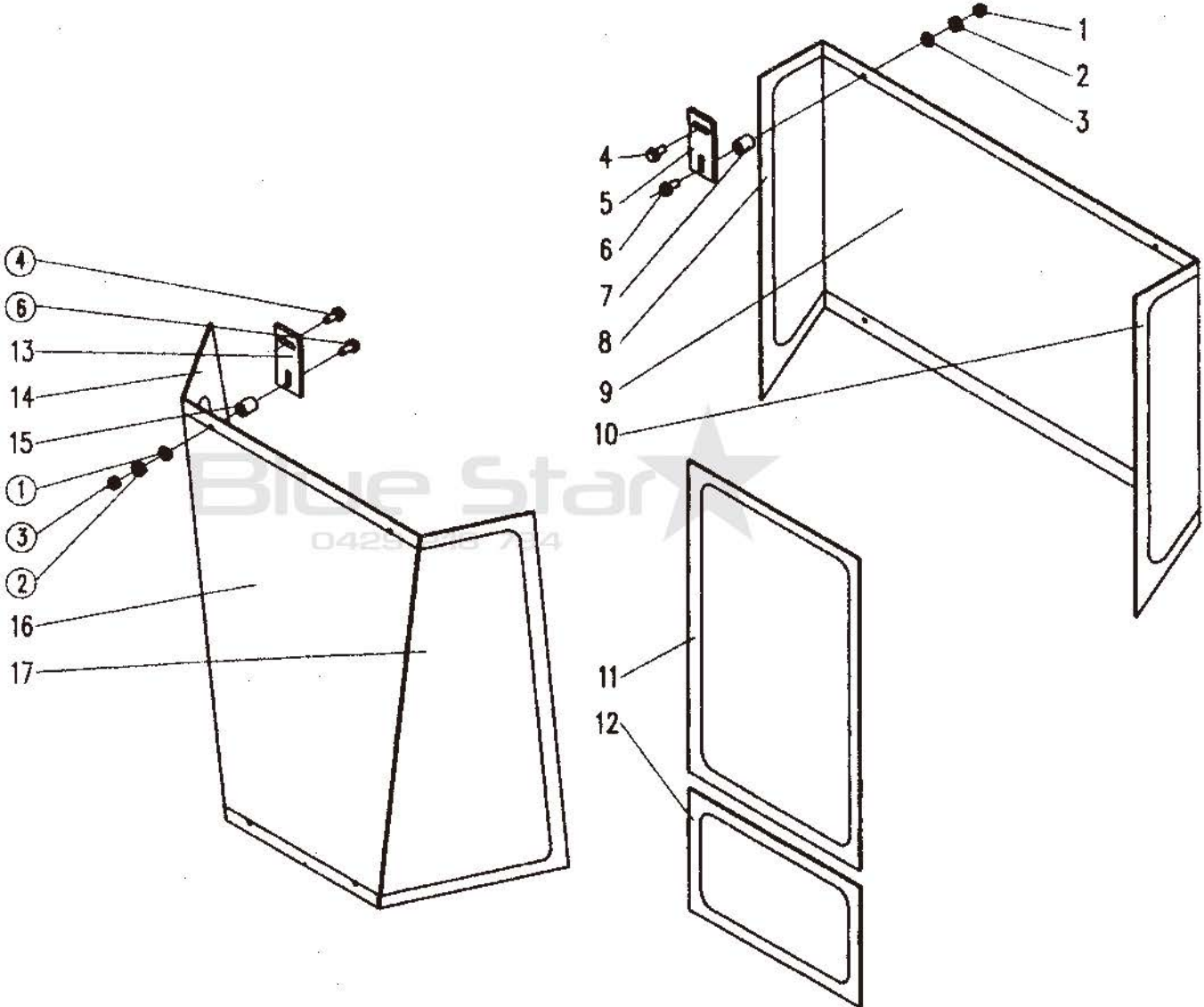

驾驶室总成 (二) Cab Assembly (Two)

序号 Ser. No	零件名称 Part Name		数量 Qty	零件代号 Part No
1	螺帽	Nut cover	8	GB6170-86
2	螺母 M6	Nut 6	8	
3	套垫 1	Gasket 1	8	
4	螺栓 M8x25	Bolt M8x25	8	GB5781-86
5	后上玻璃卡子	Backup glass checkpost	2	GB5781-86
6	螺栓 M6x45	Bolt M6x45	4	
7	套垫 2	Gasket 2	2	
8	右后侧玻璃	Right and back side glass	1	
9	后玻璃	Back glass	1	
10	左后侧玻璃	Lift and back glass	1	
11	门上玻璃	The glass above of the door	1	
12	门下玻璃	The glass nether of the door	1	
13	前上玻璃卡子	Frontup glass checkpost	2	
14	右前侧玻璃	Right and front side glass	1	
15	套垫 3	Gasket 3	2	
16	前玻璃	Front glass	1	
17	左前侧玻璃	Lift and front side glass	1	
	侧门密封条 玻璃密封条 B085 (门玻璃用) 玻璃密封条 B086 (前后玻璃用)		8.5 米 10.2 米 11.3 米	

加油机构 Accelerator Mechanism

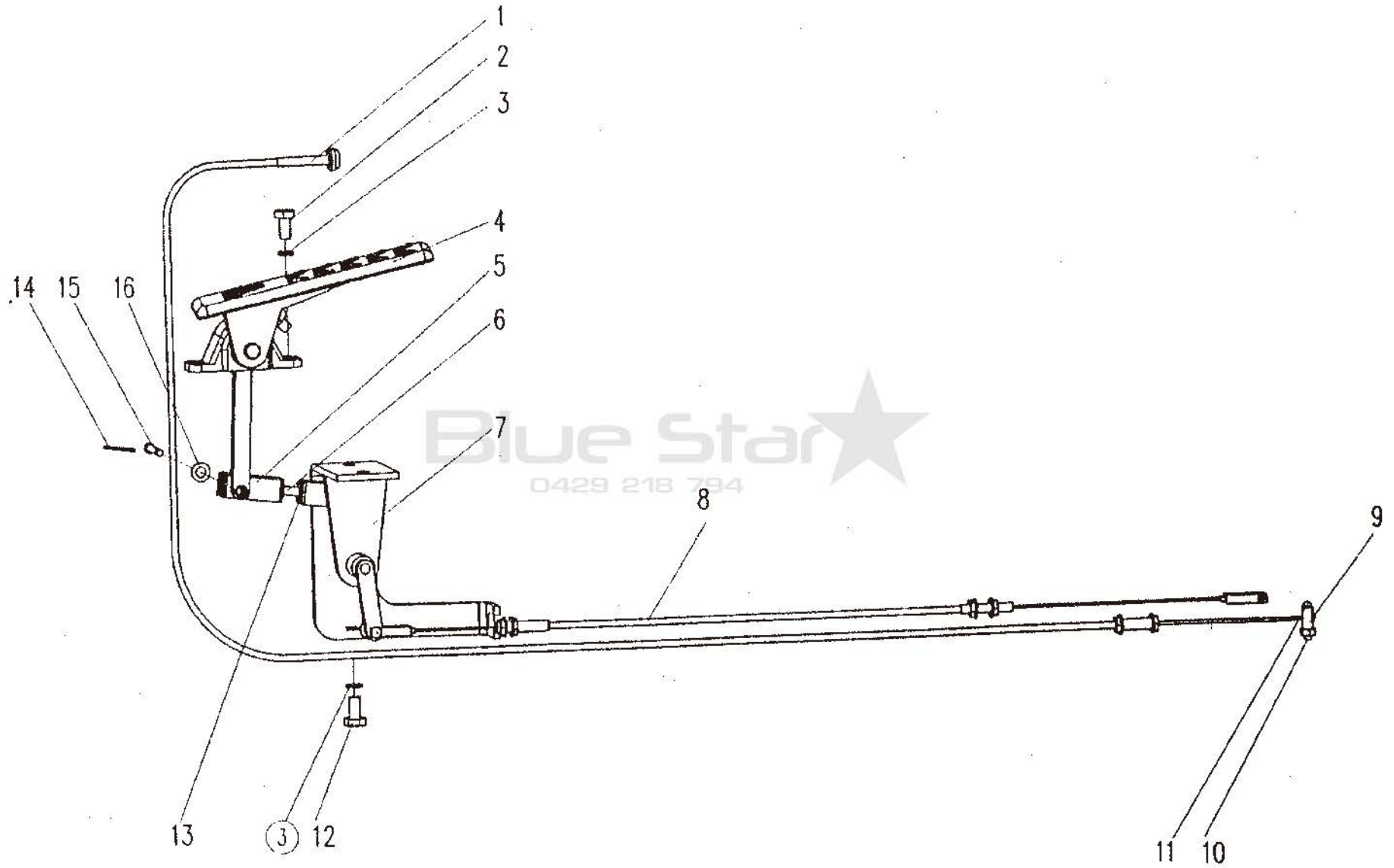

加油机构 Accelerator Mechanism

序号 Ser. No	零件名称 Part Name		数量 Qty	零件代号 Part No
1	熄火线 (3100)	Extinguishing wire	1	
2	螺栓 M10X20	Bolt M10X20	2	GB/T5783-2000
3	垫圈 10	Washer 10	6	GB93-87
4	踏脚总成	Pedal assembly	1	
5	联接叉	Join fork	2	
6	调节杆 II (ZL30D-4-9)	Adjust staff II	1	
7	加油支架总成	Accelerograph bracket	1	
8	油门踏板软轴(2380) (XC6110)	Push-pull cable (XC6110)	1	
9	紧固销	Lock Pin	1	
10	螺钉 M5×16	Bolt M5X16	1	GB75-85
11	螺母 M6-6	Nut M6-6	1	GB/T6170-2000
12	螺栓 M10X25	Bolt M10X25	4	GB/T5783-2000
13	螺母 M8	Nut M8	2	GB/T6170-2000
14	销 2X16	Pin 2 X16	2	GB/T91-2000
15	销轴 6X30	Dowel 6X30	2	GB882-86
16	垫圈 6	Washer 6	2	GB/T97.1-2002

柴油机装置 Diesel Engine Installation

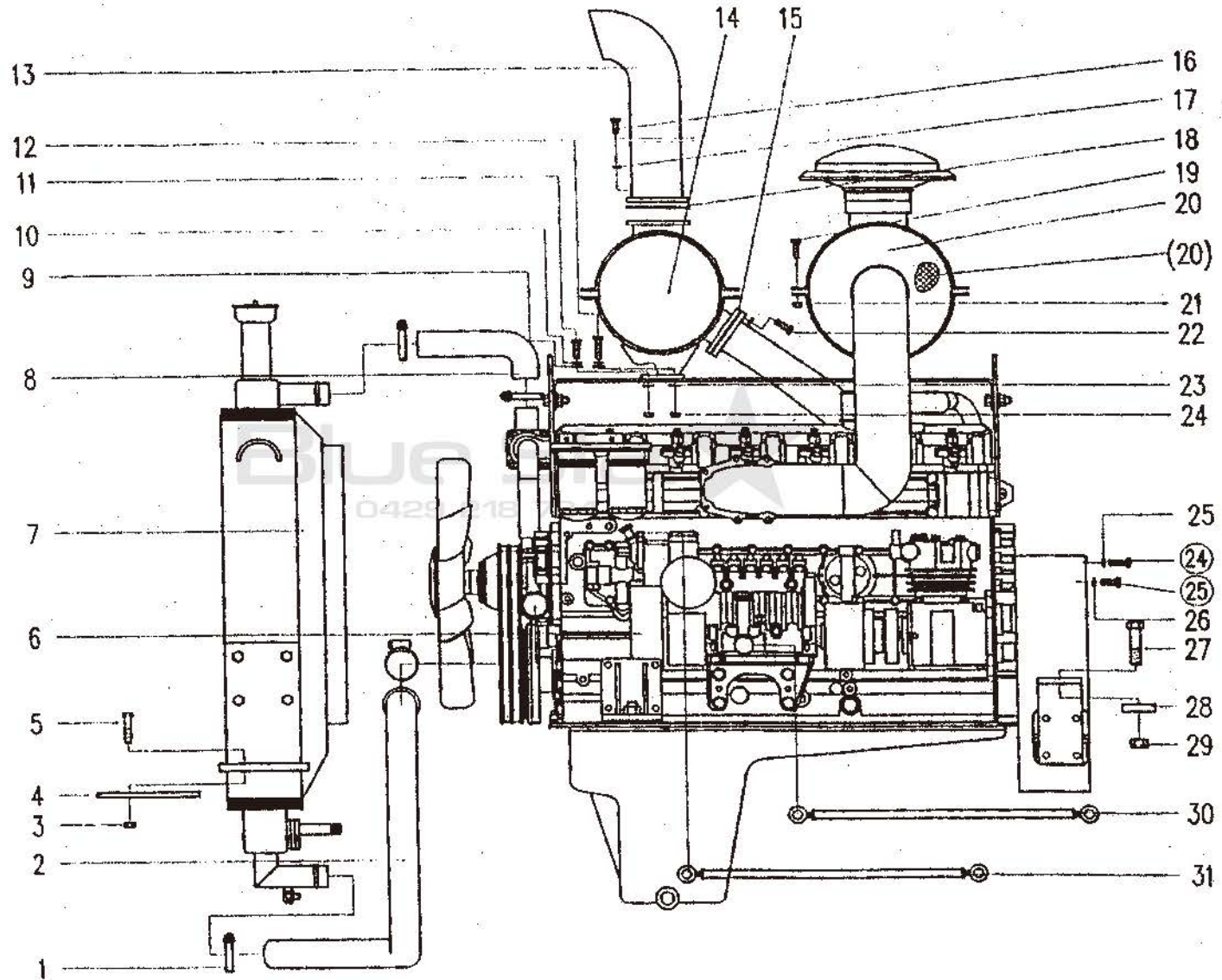

柴油机装置 Diesel Engine Installation

序号 Ser. No	零件名称 Part Name		数量 Qty	零件代号 Part No
1	喉箍 d60	Clamp d60	4	ZBJ15001-87
2	发动机进水管 (XC6110)	Engine water inlet tube	1	
	水箱出水管 (R6105)	Engine water inlet tube	1	
3	螺母 M12	Nut M12	4	GB/T889.1-2000
4	水箱减震垫	Damping spacer of radiator	4	
5	螺栓 M12×50	Bolt M12×50	4	GB5782-2000
6	柴油机 (XC6110)	Engine (XC6110)	1	
7	复合散热器 (XC6110)	Engine radiator	1	
8	发动机出水管 (XC6110)	Engine water outlet tube		
9	垫圈 8	Washer 8		GB96-85
10	垫圈 8	Washer 8	8	GB93-87
11	螺栓 M8×30	Bolt M8×30	6	GB/T5783-2000
12	螺栓 M8×35	Bolt M8×35	2	GB/T5783-2000
13	尾管	Exhaust pipe	1	
14	消音器	Muffler	1	
15	消音器垫片	Spacer	1	
16	螺栓 M10×20	Bolt M10×20	4	GB5781-86
17	垫圈 10	Washer 10	22	GB93-87
18	垫片	Spacer	1	
19	螺栓 M8×45	Bolt M8×40	8	GB/T5783-2000
20	空滤器 (KLQ-8F) (总成)	Air filter (KLQ-8F)	1	
(20)	空滤器滤芯 (KLQ-8F)	Air filter core	1	
21	螺母 M8	Nut M8	16	GB/T6170-2000
22	螺栓 M10×25	Bolt M10×25	6	GB/T5783-2000
23	垫圈 8	Washer 8	8	GB97.1-2002

柴油机装置 Diesel Engine Installation

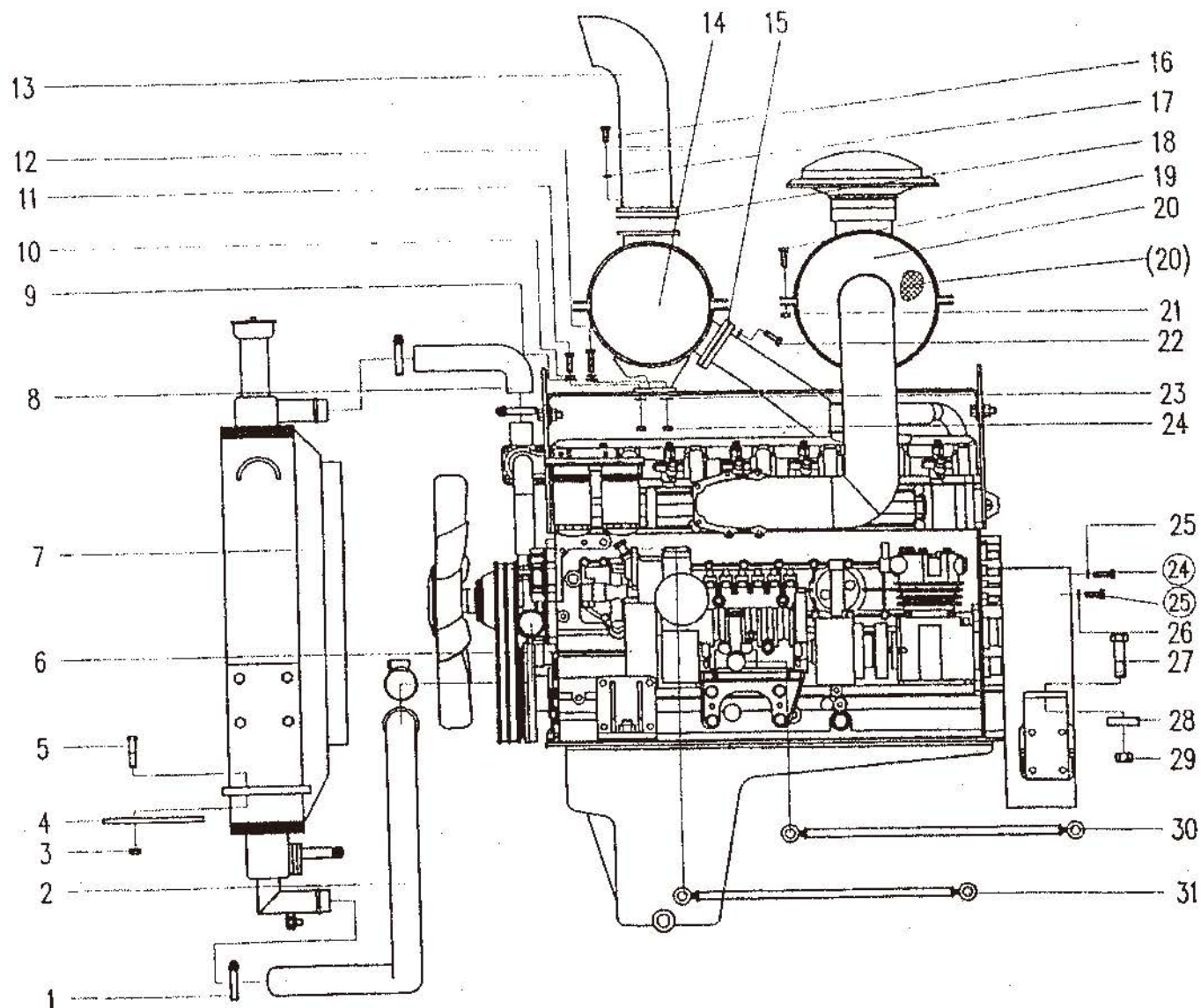

柴油机装置 (Diesel Engine Installation)

序号 Ser. No	零件名称 Part Name		数量 Qty	零件代号 Part No
24	螺栓 M10×35	Bolt M10×35	12	GB/T5783-2000
25	螺栓 M12×30	Bolt M12×30	8	GB/T5783-2000
26	垫圈 12	Washer 12	8	GB93-87
27	螺栓 M20×70	Bolt M20×70	4	GB5782-86
28	柴油机减震垫	Damping spacer of engine	4	
29	螺母 M20	Nut M20	4	GB/T889.1-2000
30	柴油机吸油管	Suction fuel tube of engine	1	
31	柴油机回油管	Return fuel tube of engine	1	



仪表盘总成 Control Panel Assembly

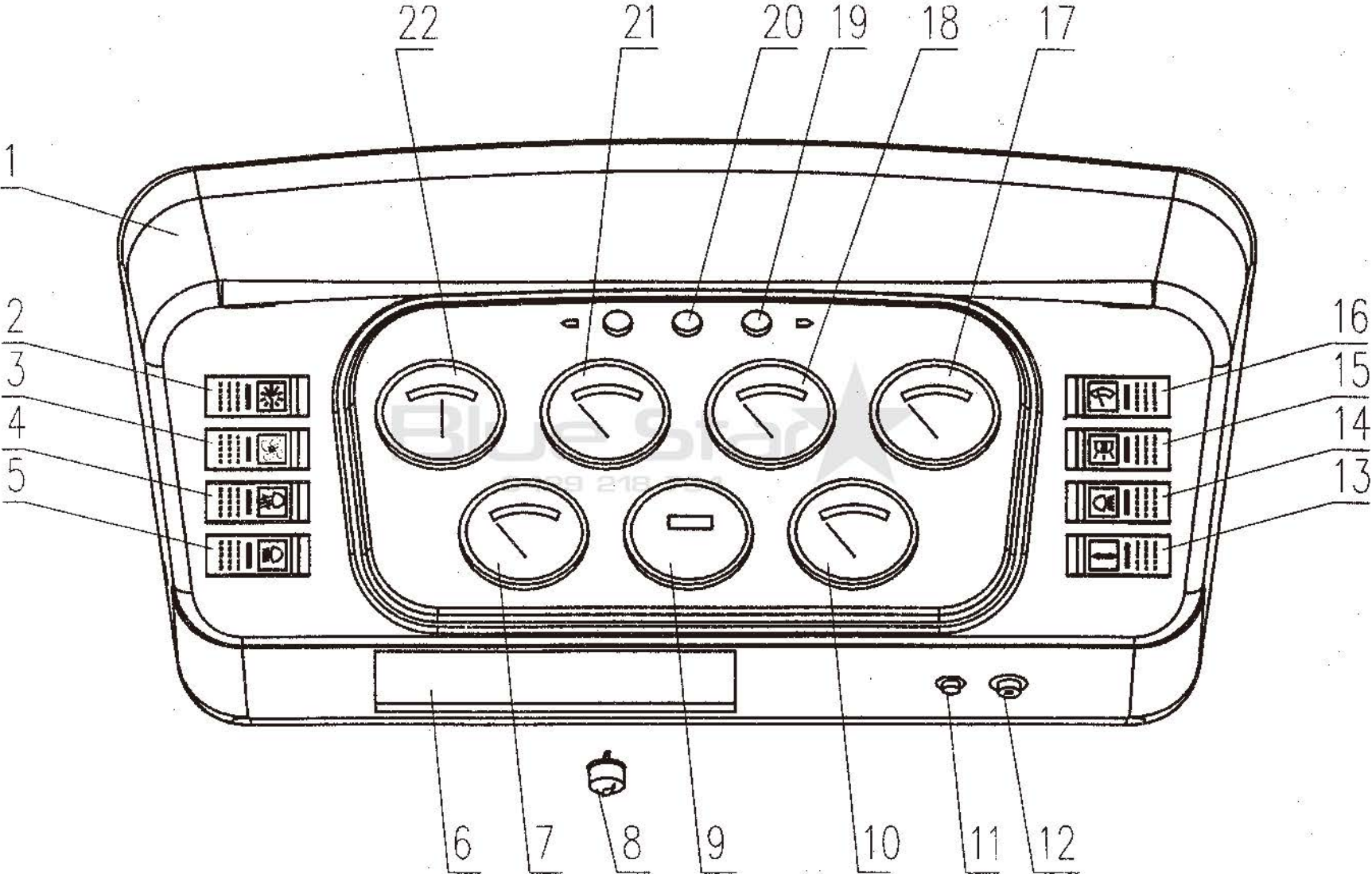

仪表盘总成 Control Panel Assembly

序号 Ser. No	零件名称 Part Name	数量 Qty	零件代号 Part No
1	仪表盘	1	
2	仪表及行车灯开关	1	JK931-3.27
3	风扇开关	1	JK931-2.8
4	防雾灯开关	1	JK931-2.21
5	前大灯开关	1	JK931-21
6	十路保险盒	1	
7	发动机水温表	1	SW22408
8	闪光器	1	SG252B (65W)
9	工时表	1	1248D2060A
10	变矩器油温表	1	YW23402
11	启动开关	1	JK260
12	电锁	1	JK404A
13	转向开关	1	JK931-146-2.3
14	后大灯开关	1	JK931
15	顶棚灯开关	1	JK931-2.58
16	雨刮器开关	1	JK931-2.5
17	气压表	1	YY07004
18	变速油压表	1	YT-202B
	变速压力表软管 (外套钢丝)	1	2400 (M10X1、M14X1)
19	转向指示灯	2	
20	刹车指示灯	1	DH16-24
21	发动机机油压力表	1	JT-202
22	电流表	1	DL93305

电器系统 Electric System

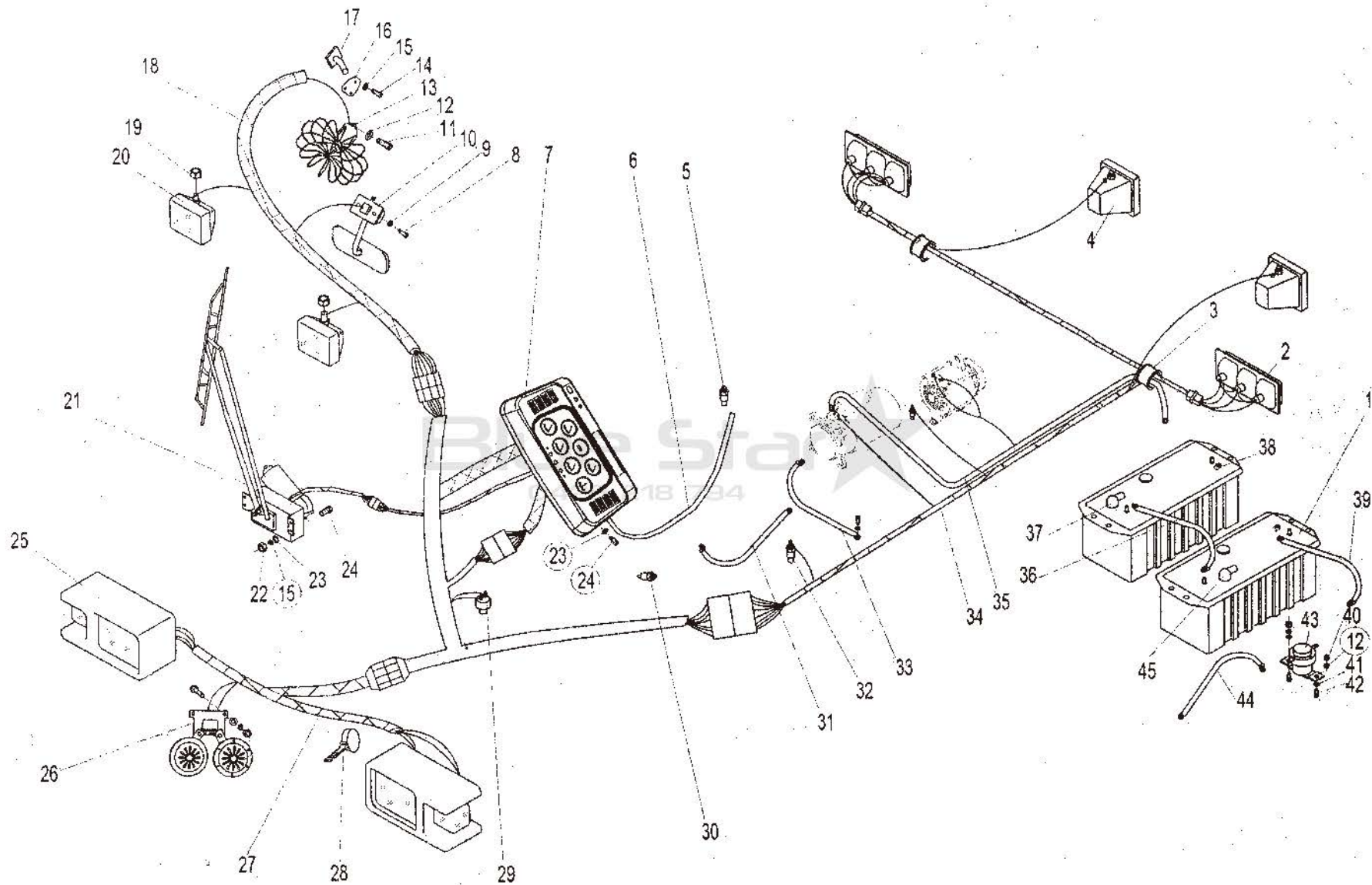

电器系统 Electric System

序号 Ser. No	零件名称 Part Name		数量 Qty	零件代号 Part No
1	蓄电池	Battery	2	3T5760
2	F后组合灯	Rear combined lamp	2	
3	护线套	Cover	10	
4	后大灯	Rear lamp	2	
5	机油压力油管接头	Adapter for engine oil pipe	1	
6	机油压力油管	Engine oil pipe	1	
7	仪表盘总成	Dash panel	1	
8	螺钉 M6X30	Screw M6X30	2	GB65-85
9	垫圈 6	Washer 6	2	GB97.1-85
10	顶棚灯(带内视镜)	Ceiling lamp(with inside mirror)	1	
11	螺栓 M10X25	Bolt M10X25	2	GB5783-86
12	垫圈 10	Washer 10	7	GB93-87
13	风扇	Fan	1	
14	螺栓 M8X25	Bolt M8X25	3	GB5783-86
15	垫圈 8	Washer 8	12	GB93-87
16	支承夹板	Supporting plank	1	
17	电风扇支座	Abutment	1	
18	顶棚线束	Wiring harness for ceiling	1	
19	螺母 M12	Nut M12	2	GB6170-86
20	防雾灯	Anti-fog lamp	2	
21	雨刮器	Wiper	1	
22	螺母 M8	Nut M8	8	GB6170-86
23	垫圈 8	Washer 8	14	GB97.1-85
24	螺栓 M8X20	Bolt M8X20	13	GB5783-86

电器系统 Electric System

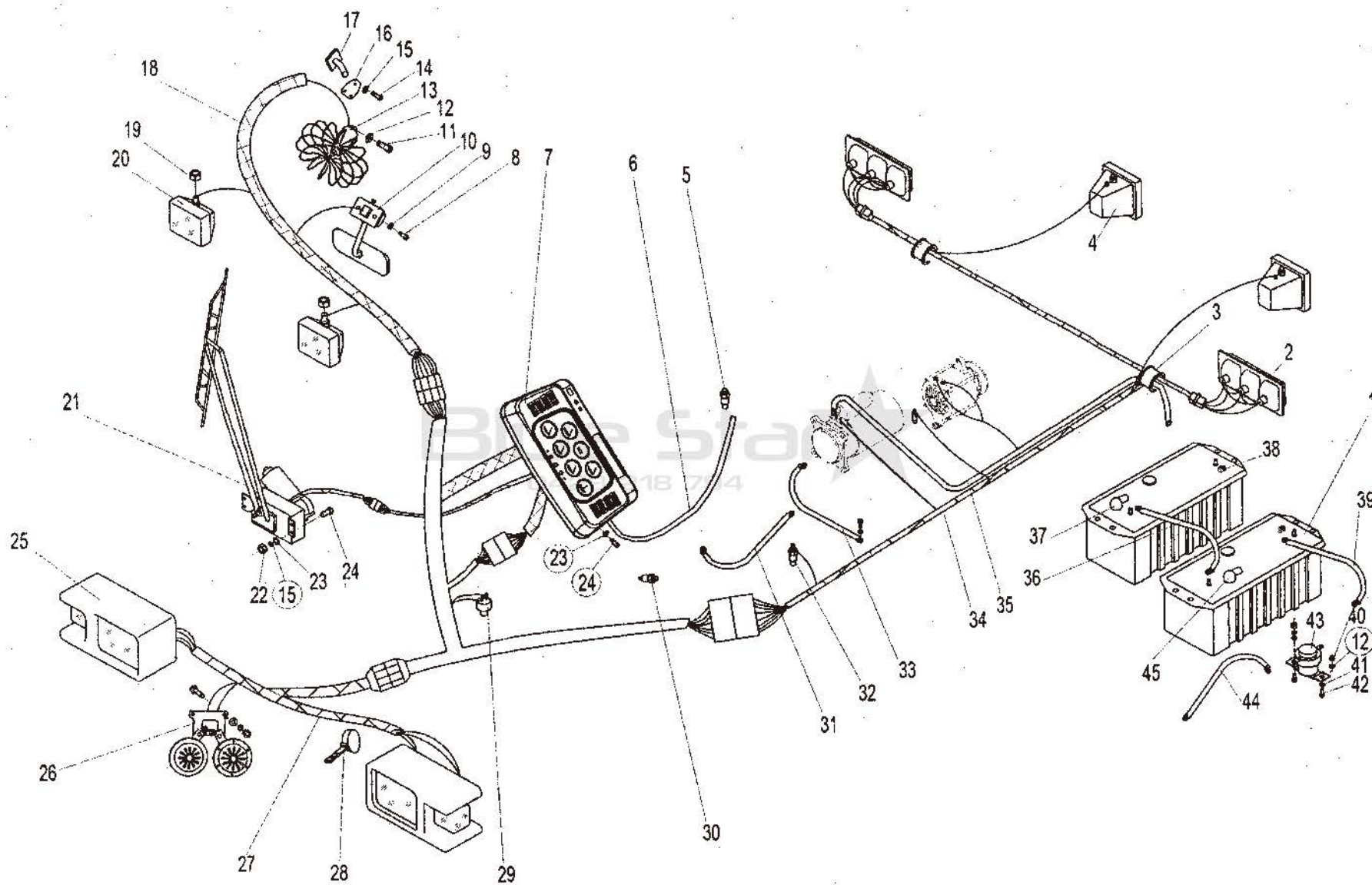

电器系统 Electric System

序号 Ser. No	零件名称 Part Name	数量 Qty	零件代号 Part No
25	F 前组合灯	2	
26	双音电喇叭	1	
27	前车架线束	1	
28	扎带 ZD300X8	4	
29	制动灯开关	1	
30	倒车灯开关	1	
31	搭铁线 400	1	
32	温度感应塞	2	
33	搭铁线 280	1	
34	后车架线束	1	
35	电瓶启动线	1	
36	电瓶连接线	1	
37	负极护套	5	
38	电瓶卡子	2	
39	电瓶负极线	1	
40	螺母 M10	2	
41	垫圈 10	10	GB97.1-85
42	螺栓 M10X20	6	GB5783-86
43	电源总开关	1	
44	电瓶搭铁线	1	
45	正极护套	3	

